

Thermo Scientific Ramsey Series 14

Precision Belt Scale System

The Thermo Scientific Ramsey Series 14 precision belt scale system is specifically designed for high accuracy or basis-of-payment applications requiring certification by government and regulatory agencies. It is extremely accurate to within $\pm 0.125\%$ and is the most widely certified belt scale in the world. This precision belt scale system lets you monitor production output and inventory, or regulate product loadout, while providing vital information for the effective management and efficient operation of your business.



The Thermo Scientific Ramsey Series 14 precision belt scale system is specifically designed for high-accuracy or basis-of-payment applications requiring certification by government and regulatory agencies.

The Ramsey Series 14 belt scale system incorporates the Thermo Scientific Ramsey 10-14 low-deflection, full-floating unitized weighbridge and the Thermo Scientific Ramsey 61-12C Belt Speed Sensor. Both are well-proven on hundreds of precision belt weighing installations.

It also utilizes the Thermo Scientific Ramsey Micro-Tech 2301 electronic integrator and the Thermo Scientific Ramsey 2301-D load cell exciter/digitizer, which are the products of 50 years of design and application experience with high-accuracy belt scales.

Applications

This highly precise belt scale system represents the world standard of accuracy and performance for loadout, inventory monitoring and fee-holder type applications requiring certification.

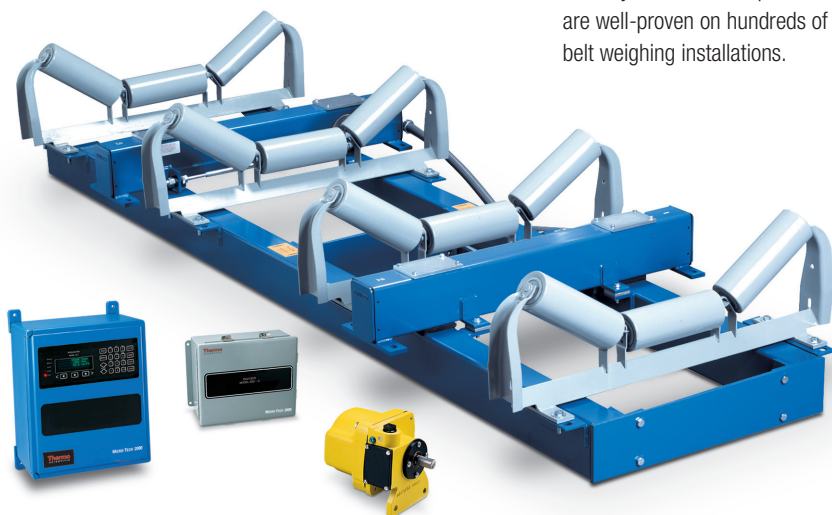

Thermo
SCIENTIFIC

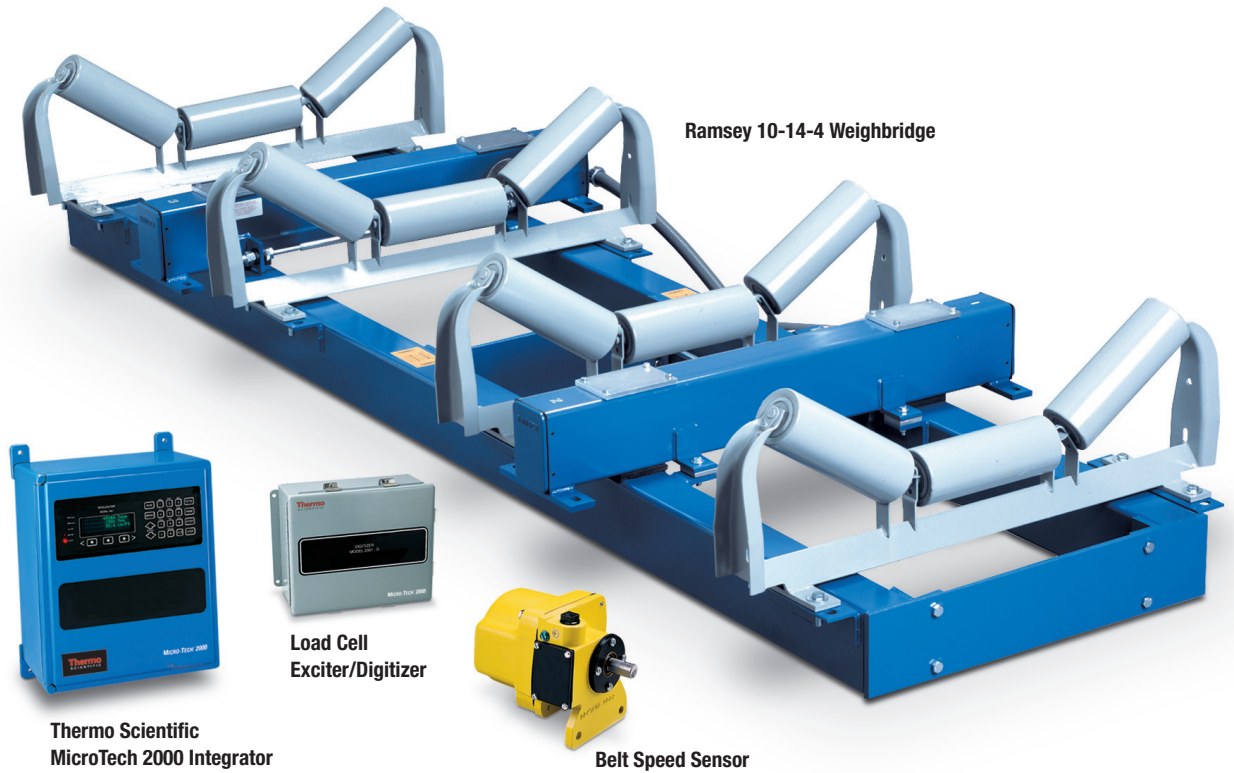

Ramsey 10-14-4 Weighbridge

Thermo Scientific
MicroTech 2000 Integrator

Load Cell
Exciter/Digitizer

Belt Speed Sensor

Features & Benefits

Certification

As the most widely certified electronic belt scale in the world, the Ramsey Series 14 has received its Certificate of Conformance in the United States as issued under the National Type Evaluation Program (NTEP) of the National Conference on Weights and Measures. Outside of the US, it is certified by OIML and EEC Class 0.5 standards.

System Components

The system has four major components: integrator, weighbridge, belt speed sensor and load cell digitizer. For more information, refer to the separate product specification sheet on the Ramsey Micro-Tech 2000 series of electronic integrators.

The Weighbridge

Three- or four-idler suspension-type Ramsey 10-14 weighbridges feature full-floating unitized assemblies with no pivots and no moving parts.

All weighbridges are constructed of structural steel tubing and are factory pre-assembled with checkrods to facilitate fast and easy field installation. Only eight bolts are required to mount the unit to conveyor stringers. Four environmentally-sealed precision strain gauge load cell assemblies are applied in tension to support the weighbridge.

The Belt Speed Sensor

The Ramsey 61-12C digital belt speed sensor is the most reliable and accurate speed-sensing device ever developed for belt scale service. Direct-coupling the sensor to the conveyor tail pulley, snubbing roll, or a large diameter return roller ensures an accurate belt-travel readout. No wheels ride on the belt, which eliminates problems related to material build-up and slippage.

The Exciter/Digitizer

The Ramsey 2301-D load cell exciter/digitizer serves as an interface from the Ramsey 10-14 weighbridge to the Ramsey Micro-Tech 2000 integrator. The unit powers the load cells and converts the analog output signals from the strain gauge load cells to an accurate, stable digital output, which provides extraordinary temperature stability. And because the output signal is digitized at the load cell, line loss is virtually eliminated and signal integrity is maintained. This unique feature is particularly important in applications where the integrator is located up to 1,219 m (4,000 ft) from the carriage.

Weighbridge Advantages

- Rigid structural steel tubing construction with checkrods maintains positive alignment

- No moving or wearing parts lead to a longer life span
- No adjustments needed
- Factory pre-assembled and easily installed
- Four strain gauge load cells applied in tension
- Full-floating, pivotless weigh platform

Belt Speed Sensor Advantages

- Rugged, cast-aluminum housing suitable for outdoor installations
- A.C. pulse generator means no brushes to adjust or replace

Exciter/Digitizer Advantages

- Housed in a NEMA 4 or 9 steel enclosure
- No adjustments or calibration required
- Digital accuracy
- Extraordinary temperature stability

Performance Guarantee

On factory-approved installations, we warrant that the Ramsey Series 14 precision belt scale system will weigh and totalize to a value within $\pm 0.125\%$ of the test load at flow rates between 25% and 100% of the scale system's calibrated capacity when calibrated against an actual weighed material test. Furthermore, we warrant that the scale system will repeat to within 0.1% of consecutively run, simulated calibration tests.

Ramsey Series 14 Precision Belt Scale – Four-Idler Weighbridge Dimensions

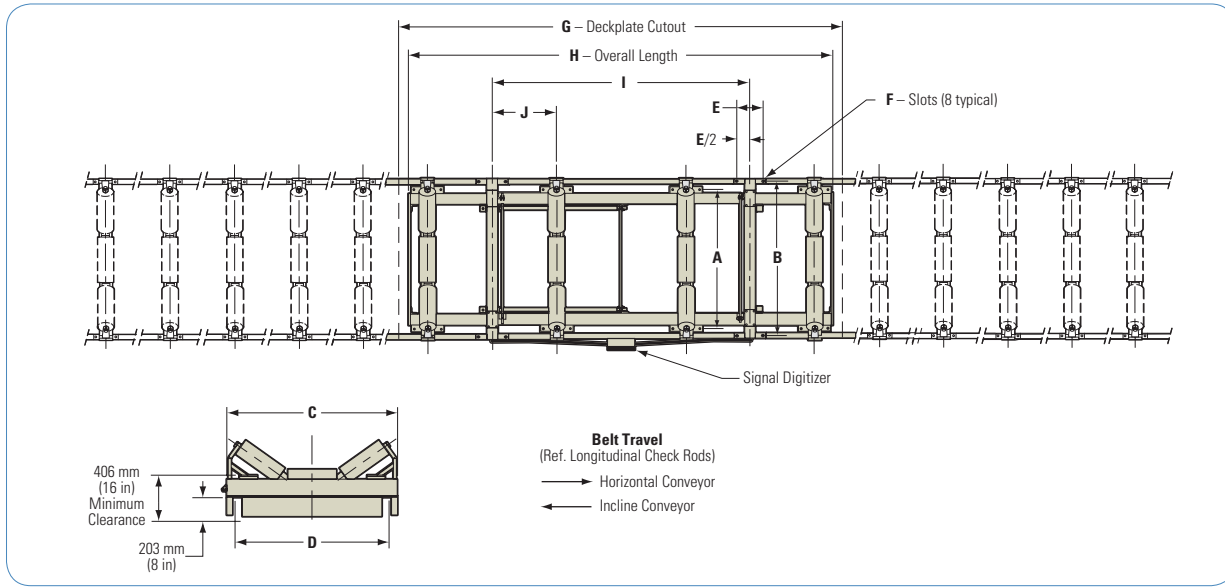

Ramsey Series 14 Precision Belt Scale – Variable Belt Width Dimensions

BELT WIDTH	LENGTH (in)					
	A	B	C	D	E	F
18 in	21.25	27	29.5	23.25	7.5	0.56 x 1
20 in	23.25	29	31.5	25.25	7.5	0.56 x 1
24 in	27.25	33	35.5	29.25	7.5	0.56 x 1
30 in	33.25	39	41.5	35.25	7.5	0.56 x 1
36 in	39.25	45	47.5	41.25	7.5	0.56 x 1
42 in	45.25	51	53.5	47.25	10	0.81 x 1
48 in	51.25	57	59.5	53.25	10	0.81 x 1
54 in	57.25	63	65.5	59.25	10	0.81 x 1
60 in	63.25	69	71.5	65.25	10	0.81 x 1
72 in	75.25	81	83.5	77.25	10	0.81 x 1
84 in	87.25	93	95.5	89.25	10	0.81 x 1

BELT WIDTH	LENGTH (mm)					
	A	B	C	D	E	F
457 mm	540	686	749	591	191	1.43 x 25.4
508 mm	591	737	800	641	191	1.43 x 25.4
610 mm	692	838	902	743	191	1.43 x 25.4
762 mm	845	991	1054	895	191	1.43 x 25.4
914 mm	743	1143	1207	1048	191	1.43 x 25.4
1067 mm	1149	1295	1359	1200	254	2.06 x 25.4
1219 mm	1302	1448	1511	1353	254	2.06 x 25.4
1372 mm	1454	1600	1664	1505	254	2.06 x 25.4
1524 mm	1607	1753	1816	1657	254	2.06 x 25.4
1829 mm	1911	2057	2121	1962	254	2.06 x 25.4
2134 mm	2216	2362	2426	2267	254	2.06 x 25.4

Ramsey 61-12 Speed Sensor Dimensions

IDLER SPACING	LENGTH (in)			
	G	H	I	J
36 in	130	122	60	12
42 in	147	139	96	27
48 in	165	158	96	24

IDLER SPACING	LENGTH (mm)			
	G	H	I	J
914 mm	3302	3099	1524	305
1067 mm	3734	3531	2438	686
1219 mm	4191	4013	2438	610

Ramsey 61-12 Speed Sensor Dimensions

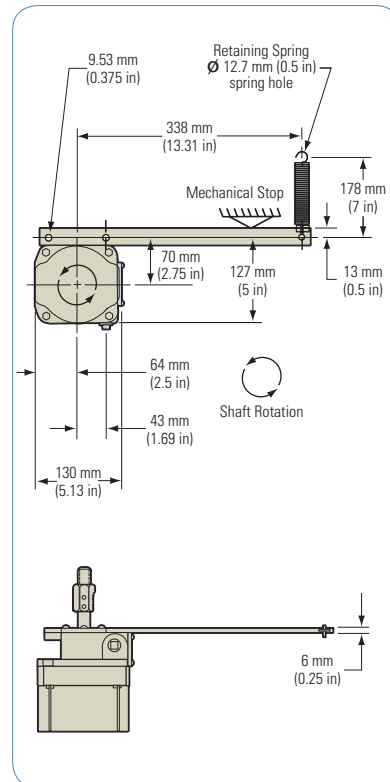

Ramsey Series 14 Precision Belt Scale – Four-Idler Weighbridge Dimensions

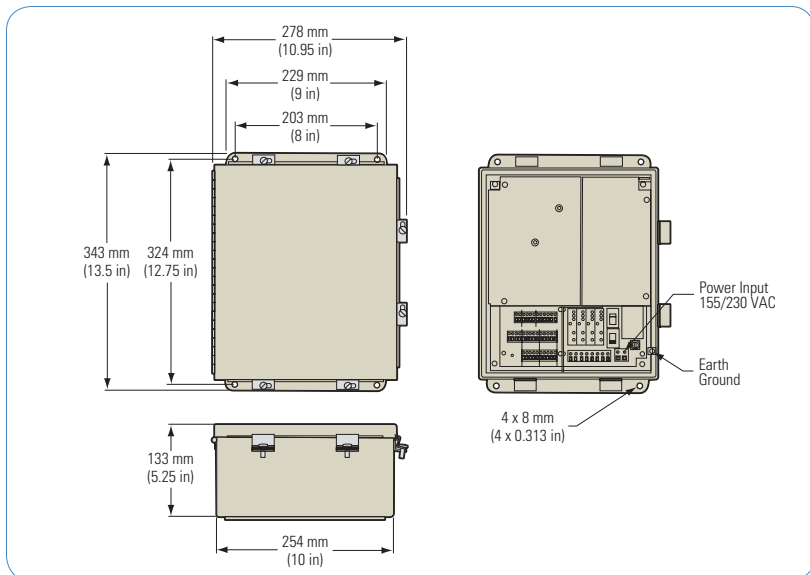

Thermo Scientific Ramsey Series 14

Ramsey 10-14 Weighbridges Specifications

Weigh Span	Three- or four-idler suspension; 2,743 mm (108 in) minimum weigh span
Clearance Requirements	Fits any standard conveyor; No space required above belt line
Idlers	Normally furnished by customer; Thermo Fisher Scientific can supply idlers upon request
Conveyors Sizes	457 mm to 2,134 mm (18 in to 84 in) or 400 mm to 2,000 mm (15.75 in to 78.75 in) belt widths
Weighbridge Construction	Mechanical steel tubing
Weighbridge Mounting	Eight bolts (four per support beam) to conveyor stringers

Ramsey 2301-D Load Cell Digitizer/Exciter Specifications

Digitizer Type	Continuous electronic load cell to digital signal digitizing
Enclosure	NEMA 4, 14-gauge steel
Circuit Construction	"68332" 32-bit microprocessor with up to 512 Kb ROM (program) and 512 Kb RAM
Power Requirements	115/230 VAC selectable, 50/60 Hz
Communication Input/Output	600, 9600, 19.2 k, 38.8 k baud RS-485; Compatible with Ramsey Micro-Tech 2301 or Ramsey Micro-Tech 2201 Integrators
Digital Input/Output	Sockets for four OPTO-22 I/O modules
Calibration	None required
Operating Temperature	-40°C to +50°C (-40°F to +122°F)
Temperature Sensitivity	-10°C to +50°C (+14°F to +122°F): Zero: 0.15 µV/°C (0.08 µV/°F) maximum Span: 4 ppm/°C (2.22 ppm/°F) maximum -40°C to -10°C (-40°F to +14°F): Zero: 0.15 µV/°C (0.08 µV/°F) maximum Span: 8 ppm/°C (4.44 ppm/°F) maximum
Accuracy	Within 0.044% of load cell capacity over full temperature range of -40°C to +50°C (-40°F to +122°F); Within 0.022% of load cell capacity over full temperature range of -10°C to +50°C (+14°F to +122°F)
Linearity	Better than 0.01% of net, for inputs from 0 to 105% of full scale
Speed Input	0-2000 Hz; Compatible with Ramsey 60 Series Speed Sensors
Isolation	Load cell and speed sensor inputs are optically isolated from other circuits

Load Cells

Quantity	Four load cells in parallel
Enclosure	Environmentally-protected "S" type cell
Mounting	Tension
Excitation	10 VDC ±5%
Output	3 mV/V ±0.1%
Non-Linearity	< 0.03% FS
Non-Repeatability	0.1% FS
Hysteresis	< 0.02% FS
Operating Temperature	-54°C to +93°C (-65°F to +200°F)
Temperature Sensitivity	Span 0.0014% FS/°C (0.0008% FS/°F) Zero 0.0027% FS/°C (0.0015% FS/°F)
Overload	Safe to 150% of load cell capacity; Ultimate to 300% FS; Sideload 50% FS
Rating	FM Approved for Class II, Div. 1 & 2, Groups E, F & G; NTEP Type III, 5000 divisions; OIML

Ramsey 61-12 Digital Speed Sensor

Type	Digital, brushless
Mounting	Direct to 15.88 mm (0.625 in) diameter stub shaft on tail pulley, bend pulley, or return roll
Housing	Weather-tight, epoxy finish, cast aluminum
Mounting Hardware	Supplied with coupling, restraint arm and restraint spring
Shipping Weight	3.6 kg (8 lb)
Approvals	FM Approved for Class I, Div. 2, Group D; Class II, Div. 1 & 2, Groups E, F & G

thermoscientific.com/bulkweighing

© 2013 Thermo Fisher Scientific Inc. All rights reserved. All trademarks are the property of Thermo Fisher Scientific Inc. and its subsidiaries. Specifications, terms and pricing are subject to change. Not all products are available in all countries. Please consult your local sales representative for details.

Australia +61 (0) 8 8208 8200 +61 (0) 8 8234 3772 fax	Chile +56 (0) 2 378 5080 +56 (0) 2 370 1082 fax	India +91 (20) 6626 7000 +91 (20) 6626 7001 fax	South Africa +27 (0) 11-822-4120 +27 (0) 11-822-3982 fax	United States & Canada +1 (800) 445-3503 +1 (763) 783-2525 fax +1 (763) 783-2500 direct
Brazil +55-11-2367-2192 +55-11-2367-2192 fax	China +86 (0) 80 0810 5118 +86 (0) 21 6445 1101 fax	Italy +39 02-950590-55 +39 02-953200-15 fax	Spain +34 (0) 91-484-5965 +34 (0) 91-484-3597 fax	
PI.8019.0513	Germany +49 (0) 208-824930 +49 (0) 208-852310 fax	Mexico +52 (55) 1253 9410 +52 (55) 1253 9424 fax	United Kingdom +44 (14) 4241 3700	

Thermo
SCIENTIFIC

Part of Thermo Fisher Scientific