

# Low Volume, Rotating Vane Flowmeter for Liquids



measuring  
•  
monitoring  
•  
analyzing

DPL



- Ranges: 0.4...8.0 to 16...400 GPH
- Linearity:  $\pm 1\%$
- Max. Pressure: 145 PSIG
- Max. Temperature: 158 °F
- Connection: G 1/2, Hose Barb
- Square Wave Pulse, Analog, or Switch Outputs
- PP Housing, Sapphire Bearings



KOBOLD companies worldwide:

ARGENTINA, AUSTRIA, BELGIUM, BULGARIA, CANADA, CHILE, CHINA, COLOMBIA, CZECH REPUBLIC, EGYPT, FRANCE, GERMANY, GREAT BRITAIN, HUNGARY, INDIA, INDONESIA, ITALY, MALAYSIA, MEXICO, NETHERLANDS, PERU, POLAND, ROMANIA, SINGAPORE, SOUTH KOREA, SPAIN, SWITZERLAND, TAIWAN, THAILAND, TUNISIA, TURKEY, USA, VIETNAM

KOBOLD Instruments, Inc.  
1801 Parkway View Drive  
Pittsburgh, PA 15205  
Main Office:  
1.800.998.1020  
1.412.788.4890  
info@koboldusa.com  
www.koboldusa.com



**Description**

The KOBOLD DPL is ideal for applications requiring a low cost, accurate means of measuring transparent liquids. With all wetted parts constructed of synthetic materials, it resists aggressive media. The compact size is ideal for situations providing minimum installation space. It is suited for a variety of industrial, commercial, and laboratory applications. The principle of operation is as follows: a jet of liquid is directed at a free running turbine in a specially shaped chamber. The blade interrupts an internal infra-red beam and converts this into a pulse output with a frequency that is directionally proportional to the rate of flow. Sapphire bearings ensure high linearity and durability.



**Technical Details**

**Accuracy:** ± 2.5% of Full Scale  
 ± 5% of Full Scale (OEM Version)

**Linearity:** ± 1% of Full Scale

**Media Temperature:** -40...158 °F

**Ambient Temperature:** -22...140 °F

**Max. Pressure:** 145 PSIG

**Protection:** IP 65

**Materials**

**Housing:** Polypropylene

**Rotating Vane:** Polypropylene

**Axle/Bearing:** Sapphire

**Vane Mount:** Polysulfone

**Gasket:** NBR, FKM, or EPDM

**Frequency Output (OEM without CE-Mark)**

**Power Supply:** 4.5 - 12 VDC

**Supply Current:** ± 7 mA

**Signal Amp. High:** Approx. Power Supply

**Signal Amp. Low:** ≤ 0.2 V

**Trans. Cut-Off Voltage:** 3 V Max.

**Trans. Supply Current:** 10 - 12 mA

**Output Loss:** Max. 2.5 mWatt

**Electrical Connection:** 5' Cable, 5-wire

**Pulse Output:** NPN, Open Collector, Max. 10 mA

**Frequency Output**

**Power Supply:** 24 VDC ± 20%

**Supply Current:** 40 - 50 mA

**Signal Amp. High:** Approx. Power Supply

**Signal Amp. Low:** ≤ 0.2 V

**Output Loss:** Max. 2.5 mWatt

**Electrical Connection:** Plug M12x1

**Pulse Output:** PNP, Open Collector, Max. 20 mA

**Analog Output**

**Power Supply:** 24 VDC ± 20%

**Output:** 4-20 mA, 3-wire

**Max. Load:** 500 Ω

**Electrical Connection:** Plug Connector M12x1 or DIN 43 650

**Option:** Plug-on Display (DIN 43 650 Only)

**Compact Electronic**

**Display:** 3-Digit, LED

**Analog Output:** 4-20 mA, Adjustable, Max. 500 Ω

**Switching Outputs:** 1 (2) Semiconductor, PNP or NPN, Factory Set

**Contact Operation:** Programmable N/C or N/O

**Setting:** Via 2 Buttons

**Power Supply:** 24 VDC ± 20%, Approx. 100 mA, 3-wire

**Electrical Connection:** Plug Connector M12x1

**Pointer Indication with Analog Output**

**Housing:** Aluminum (PA6 GF30)

**Display:** Moving Coil Instrument, 240°

**Power Supply:** 24 VDC ± 20%

**Output:** 4-20 mA, 3-wire, Factory Set

**Max. Load:** 250 Ω

**Electrical Connection:** Plug Connector M12x1



Order Details (Example: DPL-1PU1 G4 K000)

Range (GPH)	Nominal Frequency at Max. Flow (Hz)	Max. Diff. Pressure (PSI)	Model / Gasket Material			Connection	Electronics
			NBR	FKM	EPDM		
0.4...8.0	272	11	DPL-1PU1..	DPL-1VU1..	DPL-1EU1..	..G4.. = G 1/2 Male ..S4.. = Hose Barbs, 1/2" PVC	..K000 = Frequency Output, NPN, w 5' Cable (OEM), no CE-mark ..F300 = Frequency Output, Plug M12x1, PNP ..L343 = 4-20 mA Output, M12x1 Plug ..L443 = 4-20 mA Output, DIN 43 650 Plug ..C30R = LED Display, 2X Open Collector, PNP, Plug M12x1 ..C34P = LED Display, 4-20 mA, 1 Open Collector, PNP, Plug M12x1 ..Z340 = 240° Pointer Indication, 4-20 mA, Plug M12x1
0.8...28	471	11	DPL-1PU2..	DPL-1VU2..	DPL-1EU2..		
3.0...95	505	10	DPL-1PU3..	DPL-1VU3..	DPL-1EU3..		
6.0...190	265	15	DPL-1PU4..	DPL-1VU4..	DPL-1EU4..		
16...400	399	19	DPL-1PU5..	DPL-1VU5..	DPL-1EU5..		

Accessories: Part Number 807.037 = Mating 4 pin Micro-DC connector with 6 ft. cable for output ..F300 & ..L343  
 Part Number 807.007 = Mating 5 pin Micro-DC connector with 6 ft. cable for output ..C34P, ..C30R & ..Z340

Plug-On Display: for Model DPL-..L443 (4-20 mA Output, DIN Plug Connector)

Description	Model Number
4-Digit LED, Plug Connector DIN 43 650, 3-wire, Power Supply Via Analog Output	AUF-3000



Electrical Connection

DPL-..K000

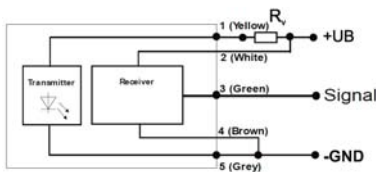

DPL-..L343, ..Z340, ..F300

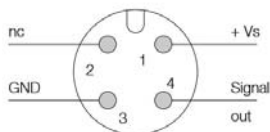

DPL-..C3xx

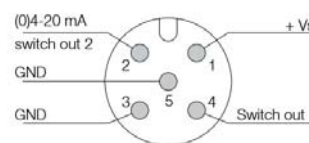

DPL-..L443

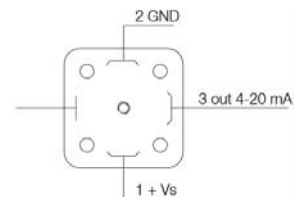



Dimensions

DPL-..K000

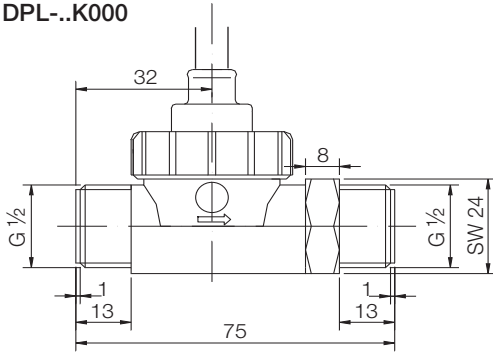

DPL-..C3xx (Compact Electronic)

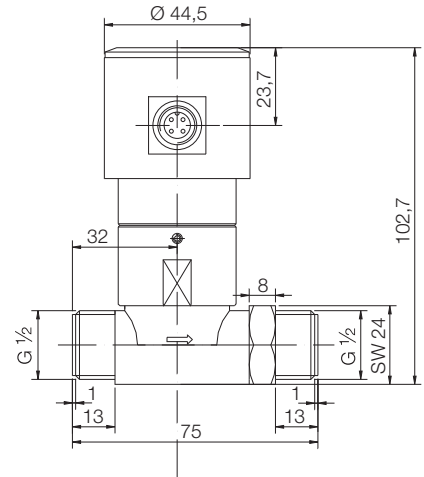

DPL-..F300, ..L343

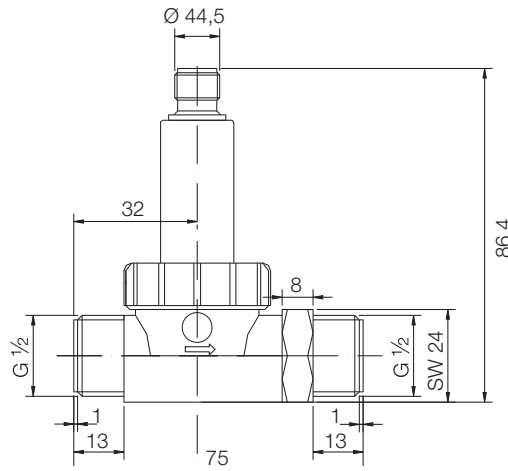

DPL-..L443 (Analog Output with AUF-3000 Plug-on Display)

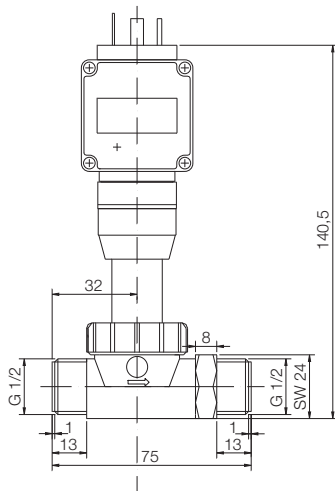

DPL-..Z340 (Analog Output and Pointer Indication)

