

Magnetic Inductive Flowmeter

All-Metal Design



measuring
•
monitoring
•
analyzing

MIM



IO-Link

- For Measurement and Monitoring of Conductive Liquids
- Flow and Temperature Measurement
- Switching, Transmitting, and Batching Functions
- Bi-directional Flow Measurement
- Rugged Stainless Steel Construction
- p_{max} : 230 PSI; t_{max} : 284 °F
- Accuracy: $< \pm (0.8\% \text{ of Reading} + 0.5\% \text{ of Full Scale})$



KOBOLD companies worldwide:

AUSTRALIA, AUSTRIA, BELGIUM, BULGARIA, CANADA, CHINA, CZECHIA, FRANCE, GERMANY, GREAT BRITAIN, HUNGARY, INDIA, INDONESIA, ITALY, MALAYSIA, MEXICO, NETHERLANDS, PERU, POLAND, REPUBLIC OF KOREA, RUSSIA, SPAIN, SWITZERLAND, THAILAND, TUNISIA, TURKEY, USA, VIETNAM

KOBOLD Instruments, Inc.
1801 Parkway View Drive
Pittsburgh, PA 15205
Main Office:
1.800.998.1020
1.412.788.4890
info@koboldusa.com
www.koboldusa.com



Magnetic Inductive Flowmeter, All-Metal Design Model MIM

Description

The new MIM electromagnetic flowmeter measures and monitors small to medium sized flow of conductive liquids in pipes. According to Faraday's Law of magnetic induction, a voltage is induced in a conductor moving through a magnetic field. The electrically conductive measured media acts as the conductor. The voltage induced in the measured media is proportional to the flow velocity and is therefore a value for the volumetric flow. The induced voltage is detected by two sensing electrodes which are in contact with the measuring media and sent to an integrated amplifier. The flow rate will be calculated based on the cross sectional area of the pipe. The measurement does not depend on the process liquid and its properties such as density, viscosity and temperature. The two outputs can be independently set to switch, or provide an analog or frequency output. A batching function can also be selected, where output 1 is set to switch as NPN/ PNP/ PP and output 2 is set as the control input.

Features

- Rugged Stainless Steel Construction
- Flow and Temperature Measurement
- Switching, Transmitting, and Batching Functions
- Batching Function with External Control Input
- Bi-directional Flow Measurement
- Colored, Multi-parameter, Configurable TFT Display, Rotatable in 90° Increments
- Intuitive Setup Menu via 4 Optical Touch Keys
- 2 Configurable Outputs (Pulse/Frequency/Alarm/Analog Output)
- Grand and Resettable Totalizer

Technical Details

Measurement Principle:	Electromagnetic
Ranges:	0.16...16 GPH to 0.4...90 GPM
Media:	Conductive Liquids
Min. Conductivity:	≥ 20 μS/cm
Native Fittings:	G 1/4...G 2, or 2" NPT
Optional Fitting Kits:	1/4"...1" NPT (Male or Female), 1" or 2" Tri-Clamp® (All Kits Include 2x Fittings and 2x Klinger SIL Gaskets except Kit ZUB-AD2G50T50 that Includes 2x Fittings and 2x FKM O-rings)
Max. Pressure:	230 PSI
Accuracy¹⁾:	< ± (0.8% of Reading + 0.5% of Full Scale)
Repeatability:	± 0.2% of Full Scale
Response Time Flow t₉₀	
Alarm/Pulse/	
Frequency Output:	< 100 ms
Analog Output:	< 1 s
Temperature Measurement	
Sensor:	PT1000
Accuracy:	< ± 35.6 °F (Flow > 0.2 m/s)
Measuring Range:	Temperature Range of the Media
Response Time Temp. t₉₀	
(Signal Output):	< 20 s
Programming²⁾:	Via 4 Optical Touch Fields, Can be used with Gloves

¹⁾ Reference Cond.: Media: 60...85 °F, 1 cSt, 500 μS/cm, 15 PSI, Ambient: 60...85°F

²⁾ Limited functionality with black rubber gloves



Mounting Position:	Universal
Inlet/Outlet:	3x Upstream, 2x Downstream
Pressure Drop:	See Pressure Loss Diagram
Housing:	316L Stainless Steel, PMMA Display Screen

Wetted Parts

Fitting/Housing:	316L Stainless Steel
Insulation Parts:	PEEK
Electrodes:	316L Stainless Steel
Seals:	FKM or EPDM
Fitting Adapter:	316L Stainless Steel

Temperature Ranges

Design	Electronics	Model	Seal	Media Temperature	Ambient Temperature
Compact Version	C3T	MIM-12	FKM	-4...158 °F	-4...140 °F
		MIM-13	EPDM		
Remote Version (PVC Cable)	P02	MIM-12	FKM	-4...185 °F	-4...140 °F (Display Electronics)
		MIM-13	EPDM		-4...185 °F (Sensor)
Remote Version (ETFE Cable)	E02	MIM-12	FKM	-4...284 °F	-4...140 °F (Display Electronics)
					-4...284 °F (Sensor)
		MIM-12	EPDM	-40...284 °F	-4...140 °F (Display Electronics)
					-40...284 °F (Sensor)

Electrical Data

Supply Voltage:	19-30 V _{DC} , Internal Power Consumption max. 200 mA
Display:	TFT Display, 128x128 Pixels, 1.4" Display, Orientation Adjustable in 90° Increments
Display Repetition Rate:	0.5...10 s, Adjustable
Pulse Output:	Push-Pull, Freely Scalable, Configurable for Partial and Accumulated Totalizer
Frequency Output:	Push-Pull, Fully Scalable, 2 kHz @ Overflow 50...1000 Hz at Full Scale, User Programmable
Alarm Output:	NPN, PNP, Push-Pull, Configurable Max. 30 V _{DC} , Max. 200 mA Short-Circuit Proof
Analog Output:	Active, 3-wire, 4-20 mA, Max. Load 500 Ω or 0-10 V _{DC} , (R _i = 500 Ω)
Control Input:	Active Signal U _{high} Max. 30 V _{DC} , 0 < Low < 10 V _{DC} , 15 V _{DC} < High < V _S



Technical Details (continued)

Batching Function: Batching Output OUT2:
 Push-Pull, High Active
 Control Input OUT1:
 START/STOP 0.5s < t_{high} < 4s
 RESET t_{high} > 5s

Shock Resistance
 DIN EN 60068-2-27:2010: 20 g (11 ms)

Vibration Resistance
 DIN EN 60068-2-6:2008: 5 g (10 ... 2000 Hz)

Environmental Testing
 DIN EN 60068-2-30:2006: Severity Level b

Protection: IP 67

IO-Link Specification

Manufacturer ID: 1105 (Decimal), 0 x 0451 (Hex)
Manufacturer Name: Kobold Messring GmbH
IO-Link Specification: V1.1
Bitrate: COM3
Minimal Cycle Time: 1.1 ms
SIO-Mode: Yes (OUT1 in Configuration IO-Link)
Block Parameterisation: Yes
Operational Readiness: 10 s
Max. Cable Length: 20 m

Order Details (Example: **MIM-12 05G G4 C3T 0**)

Model	Measuring Range ¹⁾	Native Connection	Electronics	Options
MIM-12.. = SS Housing SS Electrodes FKM Seals	..01G.. = 0.16...16 GPH ..01H.. = 0.01...1 LPM	..G2.. = G 1/4 Male	..C3T.. = Compact TFT Display 2x Configurable Outputs (Current/Voltage/Pulse/ Frequency/Alarm) M12x1 Electrical Connection	0 = Without K ⁴⁾ = Including Calibration Report
	..03G.. = 0.48...48 GPH ..03H.. = 0.03...3 LPM	..G4 ³⁾ .. = G 1/2 Male		
	..05G.. = 0.01...2.6 GPM ..05H.. = 0.04...10 LPM			
	..10G.. = 0.025...6.6 GPM ..10H.. = 0.1...25 LPM	..G5 ³⁾ .. = G 3/4 Male		
MIM-13.. = SS Housing SS Electrodes EPDM Seals	..15G.. = 0.05...13 GPM ..15H.. = 0.2...50 LPM		..P02 ²⁾ .. = Remote Display Version, TFT Display, 2m PVC Cable, Max. 185 °F	
	..15G.. = 0.05...13 GPM ..15H.. = 0.2...50 LPM	..G6 ³⁾ .. = G 1 Male	..E02 ²⁾ .. = Remote Display Version, TFT Display, 2m ETFE Cable, Max. 284 °F	
	..20G.. = 0.1...26 GPM ..20H.. = 0.4...100 LPM			
	..35G.. = 0.4...90 GPM ..35H.. = 1.5...350 LPM	..N9.. = 2" NPT Female		
	..35H.. = 1.5...350 LPM	..G9.. = G 2 Male		
Accessories: P/N 807.037 = 4-Pin Micro-DC Connector with 6-foot Cable P/N 807.037/5M = 4-Pin Micro-DC Connector with 16-foot Cable P/N 807.037/10M = 4-Pin Micro-DC Connector with 32-foot Cable				

¹⁾ Temperature units of measure factory programmed; °C for LPM models and °F for GPM/GPH models
²⁾ Order code substitution for longer cables: **020** = 2 m (6 ft), **050** = 5 m (16 ft), **100** = 10 m (32 ft), **150** = 15 m (49 ft), **200** = 20 m (65 ft).
 Wall mounting brackets (brackets incl. accessories) are included in the scope of delivery.
³⁾ Regulation (EC) No. 1935/2004 for materials and articles intended to come in contact with food. Not for connection code G9/N9
⁴⁾ Please specify number of measuring points in clear text

Electrical Connection MIM-..C3T

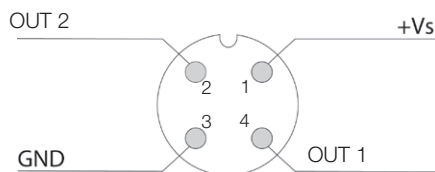

Configuration of Outputs

Output 1 (OUT1, PIN 4)	Output 2 (OUT2, PIN 2)
Analog Output 0-10 V _{DC}	Analog Output 0-10 V _{DC}
Analog Output 4-20 mA	Analog Output 4-20 mA
Switching Output NPN/PNP/PP	Switching Output NPN/PNP/PP
Pulse Output PP	Pulse Output PP
Frequency Output PP	Frequency Output PP
Communication Mode KofiCom	
Communication Mode IO-Link	
Control Input	
Control Input Start/Stop/Reset Batching Function	Batching Function Switch/PP



Order Details MIM Fitting Accessory Kits

Accessory Kit Number	Native Connection / Process Connection	Fitting Kit Type ¹⁾²⁾	Dimensions	Image
ZUB-AD2G08P08	G 1/4 Female / 1/4" NPT Male	Adapter		
ZUB-AD2U15P08	G 1/2 Cap Nut / 1/4" NPT Male	Cap Nut and Union		
ZUB-AD2G15P15	G 1/2 Female / 1/2" NPT Male	Adapter		
ZUB-AD2G15N08	G 1/2 Female / 1/4" NPT Female	Adapter		
ZUB-AD2G15N15	G 1/2 Female / 1/2" NPT Female	Adapter		
ZUB-AD2U20P15	G 3/4 Cap Nut / 1/2" NPT Male	Cap Nut and Union		
ZUB-AD2G20P20	G 3/4 Female / 3/4" NPT Male	Adapter		
ZUB-AD2G20N15	G 3/4 Female / 1/2" NPT Female	Adapter		

¹⁾ All Fitting Kits Include 2x Fittings and 2x Klinger SIL® Flat Sealing Gaskets

²⁾ Adapters and Unions are 316L SS, Cap Nuts are 304 SS

Order Details MIM Fitting Accessory Kits (Continued)

Accessory Kit Number	Native Connection/ Process Connection	Fitting Kit Type ¹⁾²⁾	Dimensions	Image
ZUB-AD2G20N20	G 3/4 Female/ 3/4" NPT Female	Adapter		
ZUB-AD2U25P15	G 1 Cap Nut/ 1/2" NPT Male	Cap Nut and Union		
ZUB-AD2U25P20	G 1 Cap Nut/ 3/4" NPT Male	Cap Nut and Union		
ZUB-AD2G25N15	G 1 Female/ 1/2" NPT Female	Adapter		
ZUB-AD2G25N20	G 1 Female/ 3/4" NPT Female	Adapter		
ZUB-AD2G25N25	G 1 Female/ 1" NPT Female	Adapter		
ZUB-AD2G25T25	G 1 Female/ 1" Tri-Clamp®	Adapter		
ZUB-AD2G50T50	G 2 Female/ 2" Tri-Clamp®	Adapter		

¹⁾ All Kits Include 2x Fittings and 2x Klinger SIL Gaskets except Kit Number ZUB-AD2G50T50 that Includes 2x Fittings and 2x FKM O-rings

²⁾ Adapters and Unions are 316L SS, Cap Nuts are 304 SS

Accessories (Spare Part)

Model	Description	Image
ERS-ZOK-023618	Stainless Steel Wall Mounting Kit for Remote Version (2 Brackets, without Nuts/Washers)	
ZUB-MIM225128	Clamping Bracket Set for Wall Mounting (Stainless Steel with Partial Polyolefin Sleeve)	

Pressure Loss Diagram

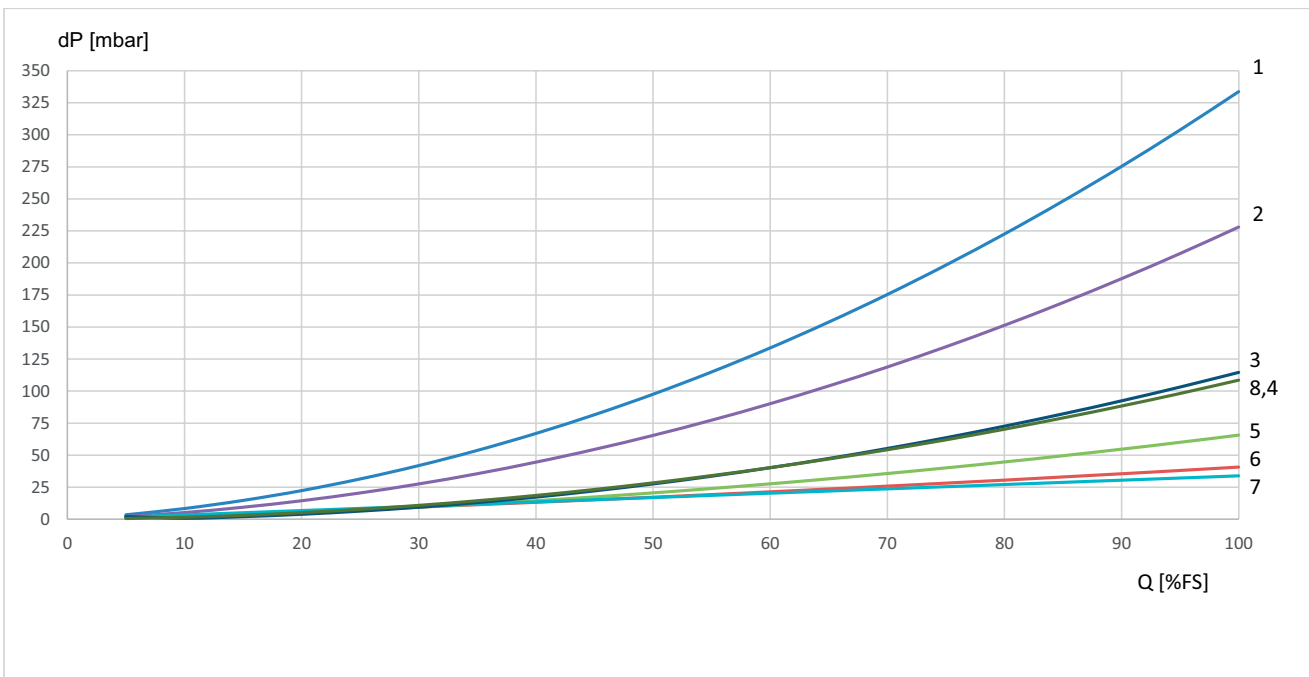

- ① MIM-1x05xG4
- ② MIM-1x15xG5
- ③ MIM-1x35xG9
- ④ MIM-1x20xG6
- ⑤ MIM-1x10xG5
- ⑥ MIM-1x03xG4
- ⑦ MIM-1x15xG6
- ⑧ MIM-1x01xG3



Measuring Mode: Display Layout "Single" Configurable

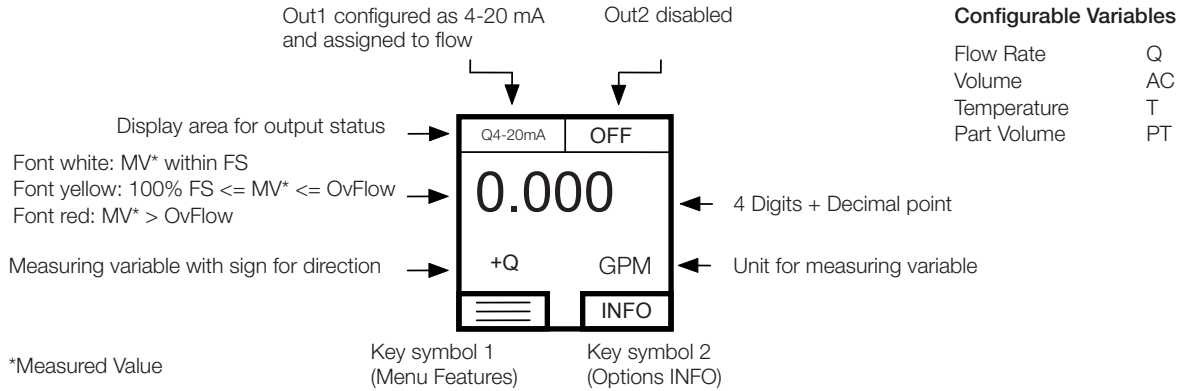

Measuring Mode: Display Layout "Dual" Configurable

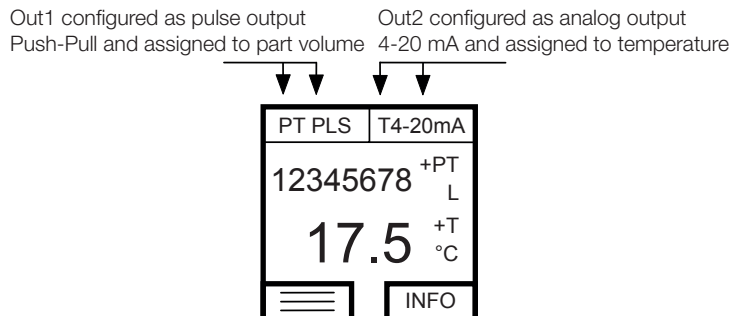
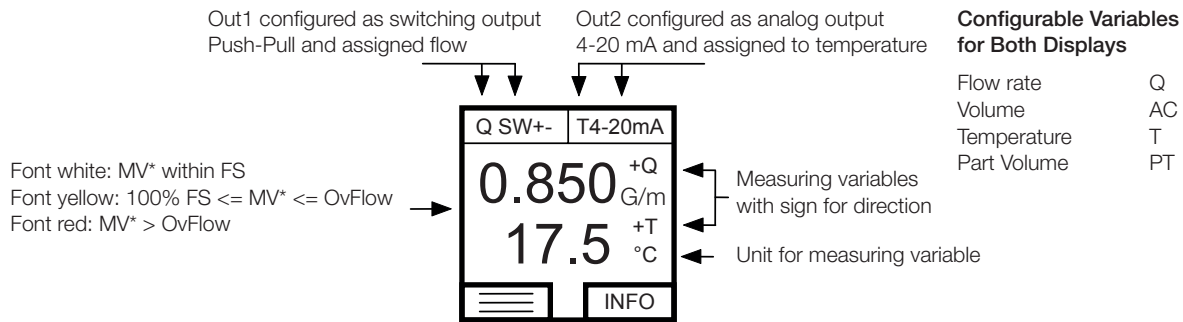



Magnetic Inductive Flowmeter, All-Metal Design Model MIM

Dimensions

Compact Version

G	Inside Diameter
1/4	2.4 x 3 mm
1/2	5 mm
3/4	10 mm
1	15 mm

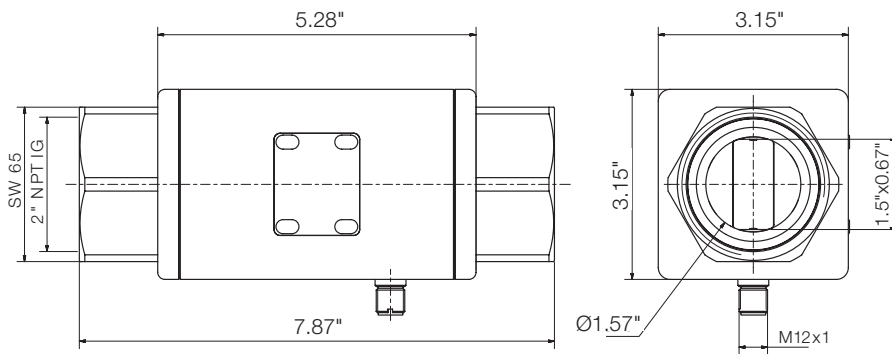
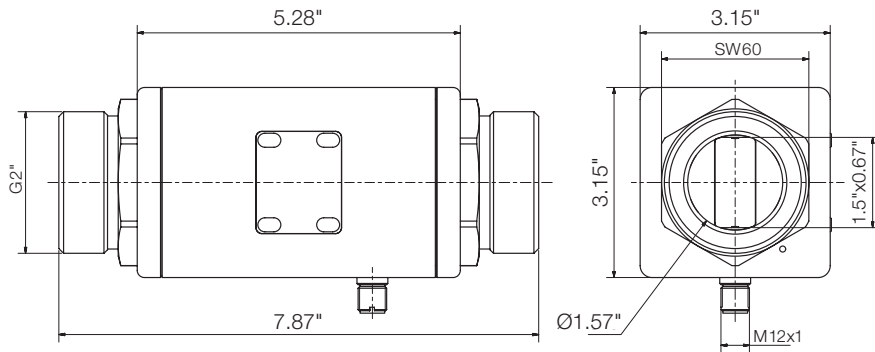
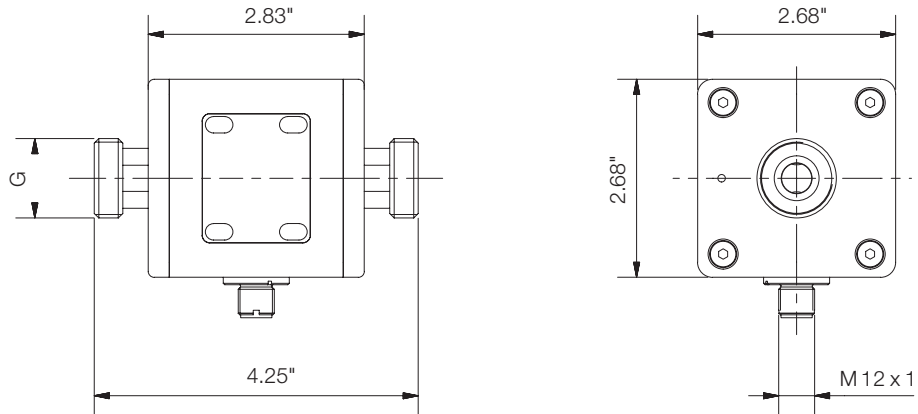

Dimensions (Continued)

Remote Version without Wall Mounting Brackets

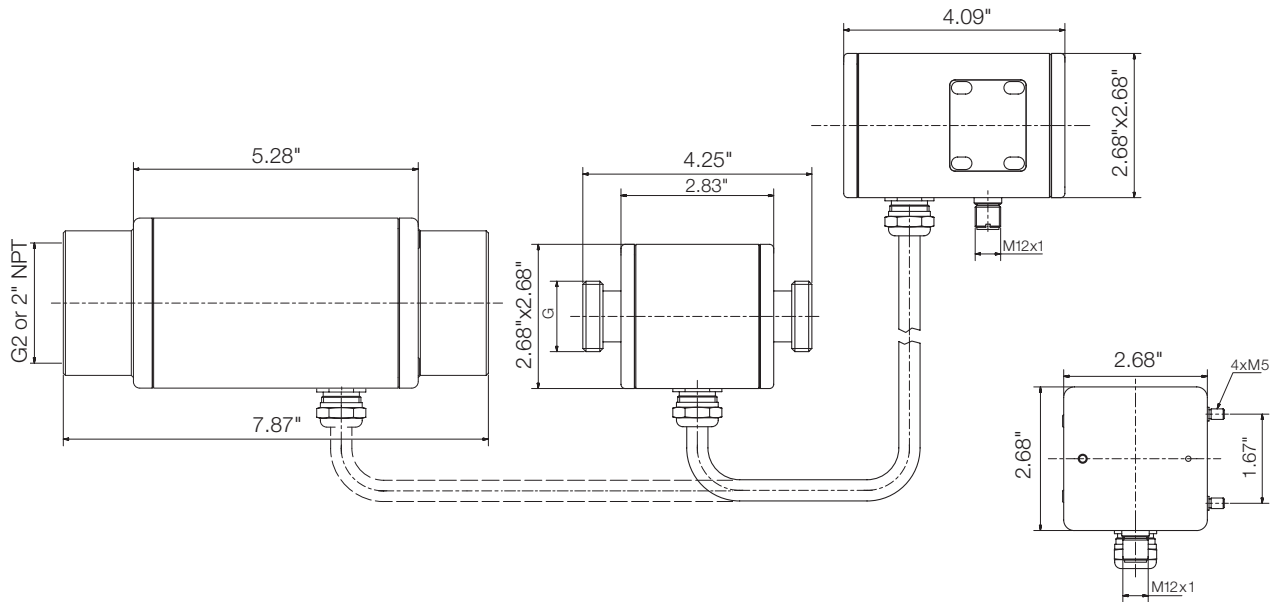

Remote Version with Wall Mounting Brackets

