



Thermo Fisher Scientific™
Speed Sensor
Model 61-12N-64P
Operating and Service Manual

REC 4374 Rev B
Part Number 136294—English

This document is confidential and is the property of Thermo Fisher Scientific. It may not be copied or reproduced in any way without the express written consent of Thermo Fisher Scientific. This document also is an unpublished work of Thermo Fisher Scientific. Thermo Fisher Scientific intends to, and is maintaining the work as confidential information. Thermo Fisher Scientific also may seek to protect this work as an unpublished copyright. In the event of either inadvertent or deliberate publication, Thermo Fisher Scientific intends to enforce its rights to this work under the copyright laws as a published work. Those having access to this work may not copy, use, or disclose the information in this work unless expressly authorized by Thermo Fisher Scientific.

Microsoft and Windows are either registered trademarks or trademarks of Microsoft Corporation in the United States and/or other countries.

All other trademarks are the property of Thermo Fisher Scientific and its subsidiaries.

© 2016 Thermo Fisher Scientific, Inc. All rights reserved.

Revision Number	Date Revised	ECO Number	Revision Specifics
Revision A	January 2014	3391	New Release
Revision B	September 22, 2016	4227	Update to Hazardous

NO CHANGES TO THIS DOCUMENT WITHOUT AGENCY APPROVAL

Table of Contents

Table of Contents	4
Introduction	5
Overview	5
Application	5
Unpacking and Inspection.....	6
Storage	6
Specifications	6
Installation	6
Overview	6
Coupling Installation	7
Restraint Arm Installation	8
Alternate Sensor Location.....	9
Operations	12
Maintenance	12
Service, Repair & Replacement Parts	14
Service and Repair Information	14
Parts Ordering Information.....	14
Parts Lists	15
Centering Template for Speed Sensor	16
Contacting Thermo Fisher Scientific	17
Appendix A – Drawings	18

Introduction

This section introduces the Thermo Scientific™ Ramsey™ Model 61-12N Speed Sensor. It gives an overview of the device's capabilities, provides information on installing, operating and maintaining along with technical specifications and reference drawings.

Overview

The Thermo Scientific Model 61-12N-64P Speed Sensor is designed and constructed for direct connection to a conveyor tail pulley, snugging roll, or large diameter return roller.

The speed sensor employs an optical pulse generator producing a stream of pulses, each pulse representing a unit of belt travel. Frequency of the pulse stream is proportional to true belt speed.



Figure 1. Model 61-12N-64P Speed Sensor

Application

The speed sensor is coupled to a rotating shaft which drives a pulse generator inside the housing. The 61-12N-64P can be used for speeds from 0 to 350 RPM. The frequency of the speed sensor output signal is exactly proportional to shaft speed and provides the required speed input to a Thermo Scientific Integrator/Totalizer.



CAUTION: The speed sensor has a coupling that is connected to a rotating shaft. Always use caution and appropriate safeguards around moving equipment.

Unpacking and Inspection

The Model 61-12N-64P Speed Sensor has been properly packaged and inspected prior to shipment. Before unpacking, be certain to check the package for external damage, as the carrier may often times be held responsible for shipping damage.

Storage

The Model 61-12N-64P Speed Sensor can be safely stored indoors, between -50 and +85 degrees C (-58 to +185 degrees F). The unit must be protected against moisture.

Specifications

Supply Voltage:	18-28 VDC
Application:	Indoor/Outdoor use
Environment Rating:	Type 4X, IP66
Supply Current:	30 mA max.
Output Current:	100 mA max. sinking current
Operating Temperature:	-40°C to +80°C (-40° to +176°F)
Speed:	T4 temperature identification
Pulse Output Rate:	350 RPM maximum
Cable Length:	64 pulses per shaft revolution
Entity Parameters for Class I, Div. 1:	20 AWG (Belden #8772 or equal), up to 500 feet (150 meters)
Humidity:	18 AWG (Belden #1036A or equal), 500 to 3000 feet (150 to 915 meters)
Pollution Degree:	Ui = 28 volts, li = 93 mA, Pi = 660 mW
Overvoltage Category:	2
Altitude:	80% maximum relative humidity for temperatures up to 31°C decreasing linearly to 50% relative humidity at 40°C.
	1
	Up to 2000m

Installation

Overview

The Model 61-12N-64P Speed Sensor must be attached to a pulley shaft which turns at true conveyor belt speed. Normally, the tail pulley shaft or a snubbing roll shaft satisfies this requirement. In installations where the tail pulley or snubbing roll shaft is not accessible, an additional pulley must be installed specifically for the speed sensor.

Coupling Installation

Two methods of coupling the speed sensor to the pulley shaft are shown in Figure 2 and Figure 3. Other methods may work as well. The most important requirement is that the speed sensor remains free floating and not rigidly coupled to the conveyor frame.

Note: Never mount speed sensor on a driven pulley.

Use the following procedures for coupling installation:

Method A:

Locate the exact center of tail pulley or snubbing roll shaft. The Centering Template for Speed Sensor located at the end of this manual may be cut out and used as a centering guide. (Refer to Figure 2.)

1. Locate circle guide over tail pulley shaft and punch center. Drill a 1-3/4" deep hole using a 17/32" drill. (Drilling a smaller pilot hole is helpful in assuring correct centering.)
2. Tap this hole using a 5/8"-11 tap.
3. Clean out oil and chips with an appropriate solvent and apply a thread lock retaining compound, such as "LOKTITE thread locker 262".
4. Thread in supplied stub shaft coupling (part #037711) so that coupling collar bottoms out against tail pulley or snubbing shaft. See Figure 2.
5. Insert 61-12N-64P speed sensor into coupling. Be sure to align shaft flat spots with set screws on coupling. Tighten all set screws securely.

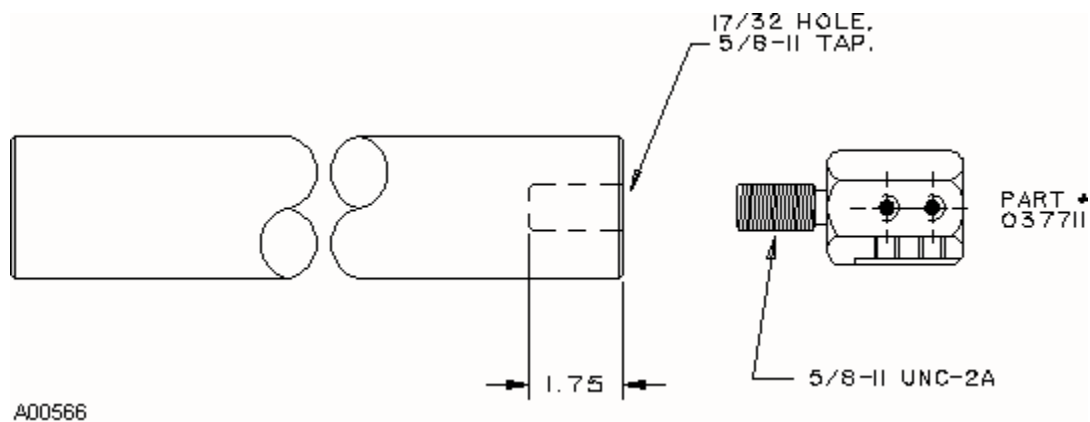

Figure 2. Method A Installation

Method B:

If customer's tail pulley shaft has a 5/8" diameter stub shaft extending from it and is concentric with the centerline of the driving shaft, use part #002931 to couple 60-12 speed sensor to tail pulley shaft (refer to Figure 3). This coupling is not supplied with the speed sensor but may be purchased separately from Thermo Fisher Scientific.

It would be advisable to provide two flat surfaces, 90° apart, on the stub shaft for a good set screw holding power.

Note: If possible, weld coupling to tail pulley shaft. Do not weld to any part of 61-12N-64P speed sensor.

Align shaft flat spots with set screws on coupling. See Figure 3. *Tighten all set screws securely.*

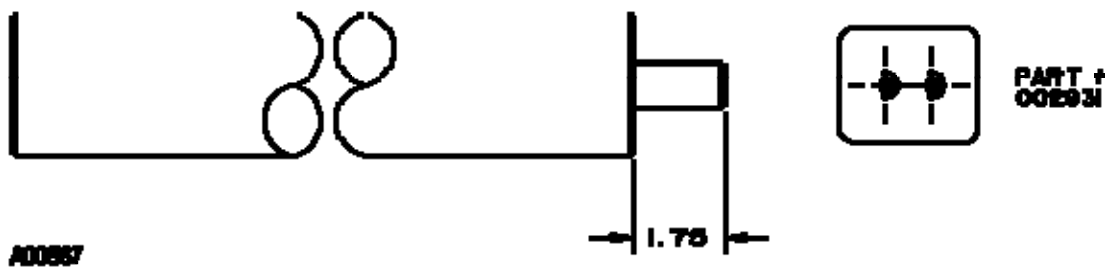

Figure 3. Method B Installation

Restraint Arm Installation

1. Attach restraint arm to speed sensor with two (supplied) 5/16" x 1-1/4" bolts. See Figure 4. The restraint arm should be mounted in a direction that will allow the sensor restraint arm to twist against the mechanical stop and in the direction of belt travel.
2. Weld or otherwise secure an appropriate mechanical stop such as a piece of scrap iron (or a bolt) to the conveyor frame. Rotate restraint arm to let it rest on the stop. See Figure 4. Make the mechanical stop large enough to accommodate some lateral movement of the restraint arm.
3. Fit one end of the supplied restraining spring through the hole in the end of the restraint arm. Attach the other end to the conveyor frame. Location should be such as to give a 1/2 inch spring stretch. Do not over-tighten spring as this may cause premature failure. See Figure 4.
4. Although not required, it is recommended that a rock or step shield be fabricated and installed around the speed sensor.
5. Do not connect power to the machine or turn on the unit until you have read and understood this entire chapter. The precautions and procedures presented in this chapter must be followed carefully to prevent equipment damage and protect the operator from possible injury.

Note: The purpose of this mounting arrangement is to allow the speed sensor to “float” and accommodate any slight misalignment of the coupling. Therefore, no resultant bearing stress is applied due to misalignment, nor will a slight “wobble” of the device result in electrical errors.

Alternate Sensor Location

On installations where the tail pulley or snubbing roll shaft is not accessible and additional pulley must be installed specifically for the speed sensor. When using an additional pulley for the speed sensor, the following requirements are essential:

1. Select the proper pulley diameter to provide a shaft RPM within the range of the speed sensor (at rated belt speed or over the range of belt speeds that are of concern).
2. Locate the pulley on the clean side of the return belt to minimize material build up on the pulley.
3. Install the unit in such a manner as to provide 15 to 30 degrees contact wrap on the pulley. Any slippage between belt and pulley will decrease the belt scale accuracy.



CAUTION. Unless the installation is consistent with the illustrations shown in *Figure 2, Figure 3, Figure 4,* and as described above, the warranty on the device is void.

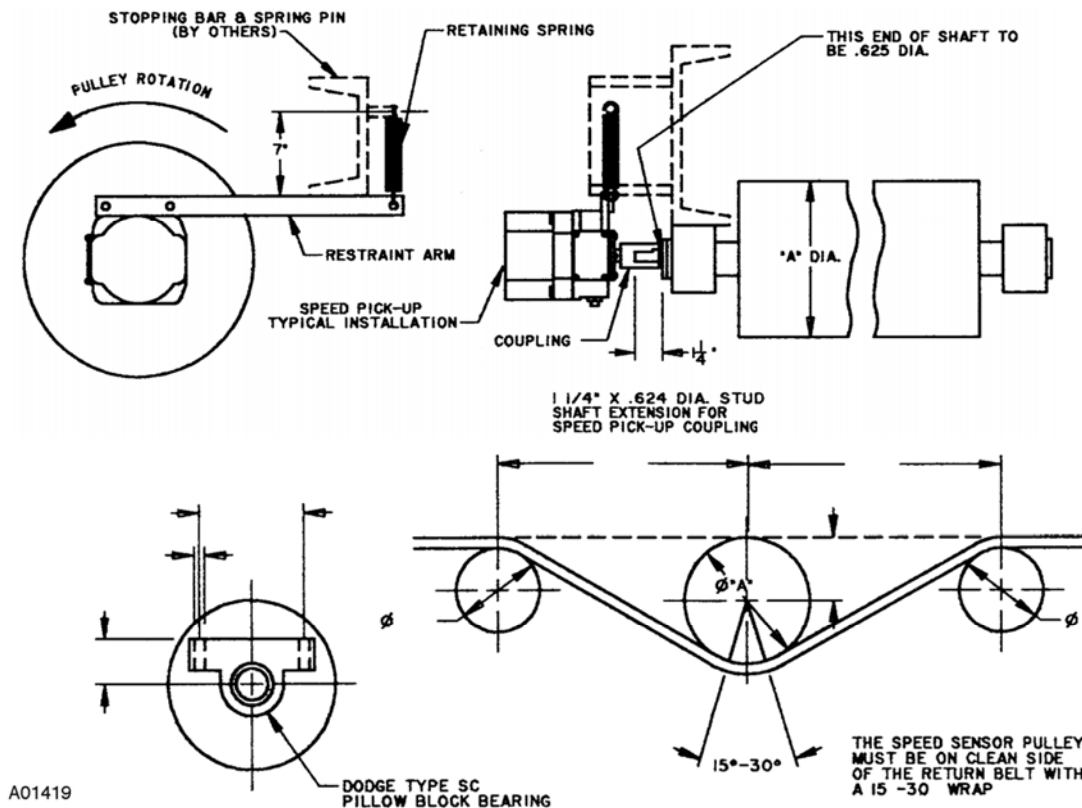

Figure 4. Mounting Illustration

1. Speed Sensor must not be mounted rigid. Use restraint arm and retaining spring. Mechanical stop and spring mount are by others.
2. Attach spring in location such as to give 1/2" spring stretch.
3. All wiring by others in accordance with system field wiring diagram and applicable codes.

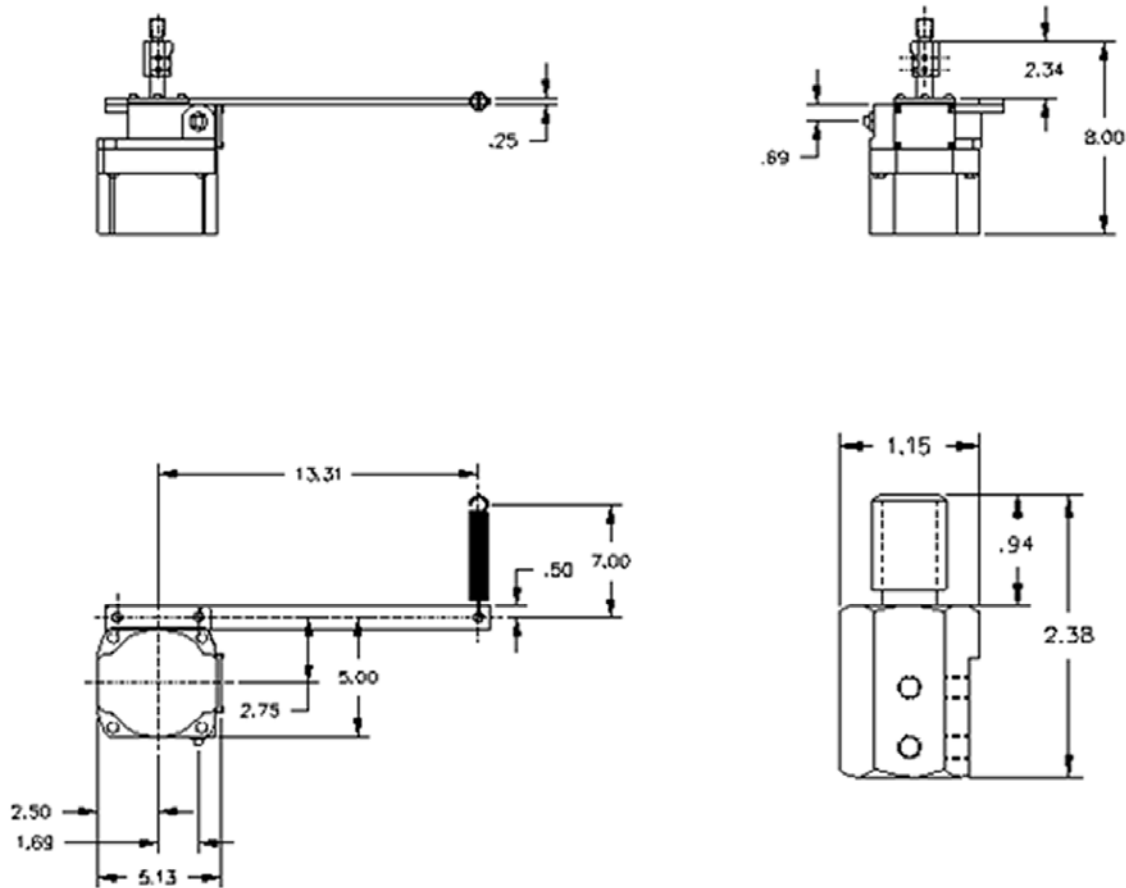

Figure 5. Outline and Mounting Dimensions

Notes:

1. Speed Sensor to be driven by conveyor tail pulley shaft or by special return roll.
2. Unit must be directly coupled to driving shaft. Do not drive with chains, belts, gears, etc.
3. Customer to provide tapped hole 1.75" deep.
4. Do not rigid mount speed sensor.

Electrical Wiring

Use the following procedures to make electrical connections:

1. Remove the terminal strip cover (Figure 1) and the dust plug from the threaded conduit aperture in the speed sensor housing.
2. Install 1/2 inch flexible conduit to the speed sensor housing.
3. For 61-12N-64P use Belden 8772 or equivalent, 3 conductor, 20 AWG, shielded. Maximum distance is 500 feet (150 meters). For distances of 500 to 3000 feet (150-915 meters), use Belden #1036A or equivalent, 3 conductor, 18 AWG shielded. Cable temperature rating must exceed minimum and maximum ambient conditions.
4. Do not put speed sensor cables in the same conduit as power wiring.
5. Connect one wire to each of terminals 15, 16, and 17 as shown in Figure 6. Replace the terminal strip cover.



CAUTION: The three wires connecting the speed sensor to the integrator/totalizer must be shielded. Refer to system wiring diagram for proper shield termination.

6. Do not terminate cable shield at speed sensor. Follow system field wiring diagrams for termination at control instrument only.
 - Refer to drawing 07392BE041 at the end of this manual for Class I hazardous location installations.
 - Refer to drawing 07392BE042 at the end of this manual for Class II or III hazardous location installations.
 - Refer to drawing 07392BE043 at the end of this manual for non-hazardous area location installations.

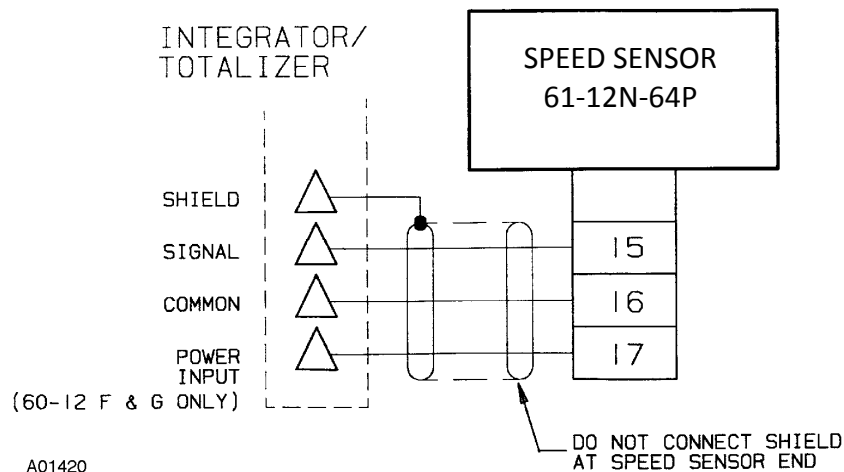

Figure 6. Field Wiring

Operations

Overview

The speed sensor element employs an optical, pulse generator which produces a stream of pulses, each pulse representing a unit of belt travel. The frequency of the pulse stream is proportional to true belt speed. The pulse output signal is fed to the Integrator/Totalizer.

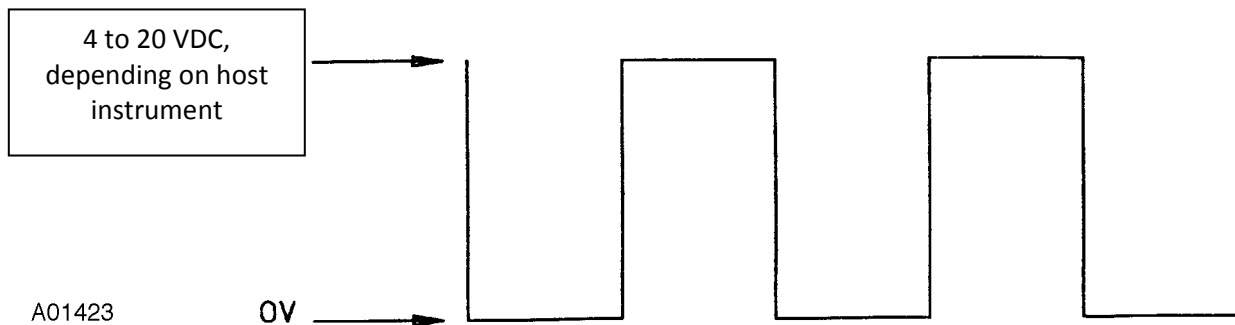

Figure 7. 61-12N-64P Output Voltage Waveform

Model 61-12N-64P

The 61-12N-64P has a 64 pulse per revolution optical encoder and can be used for speeds from 0 to 350 RPM. The output of the 61-12N-64P is an “open-drain” type, which requires an external pull-up resistance. Nearly all Thermo Scientific Belt Scale Integrators provide this pull-up resistance internally.

Maintenance

Overview

When performing scale calibration, it is a good practice to inspect the shaft coupling for tightness. Inspect the shaft seal yearly for damage and cracks. If the shaft seal is defective, replace the speed sensor. Also verify that the restraint arm is free to move. If arm has worn a slot in the restraint stop and the restraint bar cannot float back and forth as well as against the spring, corrections should be made.

Calibration

No adjustment or calibration of the device is necessary.

Troubleshooting

1. Place a DC voltmeter across field terminals 17 (+) and 16 (-) of 61-12N-64P speed sensor.
2. Reading should be equal to the source voltage from the integrator.
3. If no voltage present, check at integrator terminals (see scale integrator manual).
4. If voltage is present, check field wiring. If no voltage present, repair or replace integrator.
5. Place AC voltmeter across field terminals 15 and 16 of 61-12N-64P speed sensor.
6. With conveyor stopped, output should be 0.0 VAC.
7. Start conveyor belt; output should be greater than 4 VAC.
8. If no voltage is present, check the sensor with the wire from terminal 15 disconnected.
9. If no voltage is present while running, repair or replace the speed sensor.
10. If greater than 4 VAC is present, check field wiring.

Service, Repair & Replacement Parts

This section provides information about service, repair and replacement parts for your TMD IV. It includes the telephone numbers for various departments at Thermo Fisher Scientific. The procedure for ordering replacement parts is also included in this section.

Service and Repair Information

The maintenance information in this manual is designed to meet your service needs. If you should encounter a problem that requires technical assistance, you may call Thermo Fisher Scientific Product Service at (800) 445-3503.

Thermo Fisher Scientific also provides on-site service technicians to assist customers with installation, set up, initial calibration, customer training, maintenance, and repair. Contact the Field Service department at the number given below for current rates and scheduling.

Thermo Fisher Scientific has a repair center located at our plant in Minneapolis, Minnesota. Products that need system checkout or repair can be returned to the plant with the Return Material Authorization (RMA) form. Contact our Repair and Returns department at (800) 445-3503 to get an RMA form and number.

Note: Have your machine model number and serial number available when you call.

Main Switchboard	(763) 783-2500
FAX	(763) 783-2525
Technical Assistance	(800) 445-3503
Field Service	(800) 445-3503
Return Material Authorization & Repair	(800) 445-3503
Website Contact Us	www.thermofisher.com/bulkweighing

Parts Ordering Information

For the fastest service when ordering parts, telephone or fax the Thermo Fisher Scientific Parts Department at the numbers given below. Your regional field service representative can also assist you with parts orders, but this may delay shipment of your parts.

The recommended procedure for ordering parts is:

1. Determine the broken or faulty part.
2. Locate the part on the engineering drawings referenced in Appendix A.
3. Find the corresponding part number in the parts list.
4. Before you contact Thermo Fisher Scientific for your parts, make sure you have the following information:
 - Machine model and serial number
 - Purchase Order number
 - Date required
 - Preferred shipping method
 - Part number(s), description, and quantity needed
5. Contact Thermo Fisher Scientific by email, fax, or telephone.

Parts Lists

The list below provides part numbers and descriptions of the replaceable parts for the 61-12N-64P Speed Sensor.

ITEM DESCRIPTION	PART NO.
61-12N-64P (64 pulse, 24 VDC)	133748
Clamp Bar (Restraint Arm)	002920
Coupling, Stub Shaft, Speed Sensor	037711
Coupling Shaft, .625 Bore	002931
Spring, Extension for Clamp Bar	001988
Cover, Junction Box	004156

Centering Template for Speed Sensor

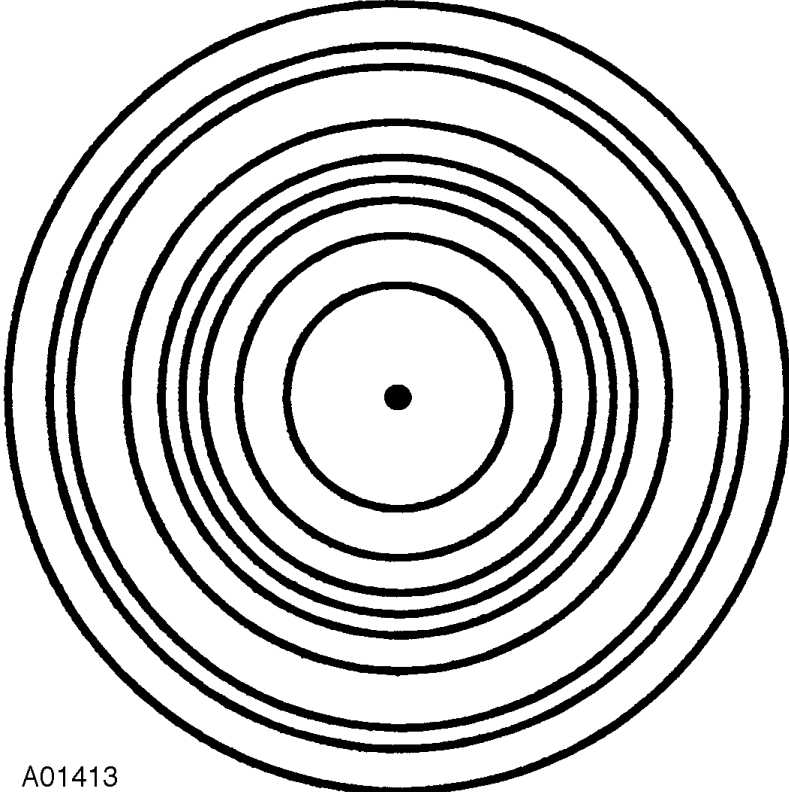

A01413

Contacting Thermo Fisher Scientific

Here's how to contact us for replacement parts or technical support. We are here to help!

Australia

+61 (0) 8 8208-8200
+61 (0) 8 8234-3772 fax
sales.auadl@thermofisher.com

Chile

+56 2 378 5080
+56 2 370 1082 fax
sales.bmh@thermofisher.com

China

+86 8008105118
sales.bulk.us@thermofisher.com

Germany

+49 (0) 208-824930
+49 (0) 208-852310 fax
sales.oberhausen@thermofisher.com

India

+91-22-4157-8800
+91-22-4157-8801 fax

Italy

+39 02-950590-55
sales.mi.ramsey.it@thermofisher.com

Mexico

+52 55 3600 1599
mxnau.sales@thermo.com

South Africa

+27 11 776 0000
+27 11 822 3982 fax

Spain

+34 91-484-5965
+34 91-484-3597 fax

United States

+1 (800) 445-3503
+1 (763) 783-2500
sales.bulk.us@thermofisher.com

Appendix A – Drawings

List of drawings

- Drawing 07392BE041
- Drawing 07392BE042
- Drawing 07392BE043

ITEM	PART NO	QTY	DESCRIPTION	DWG NO/SPEC
------	---------	-----	-------------	-------------

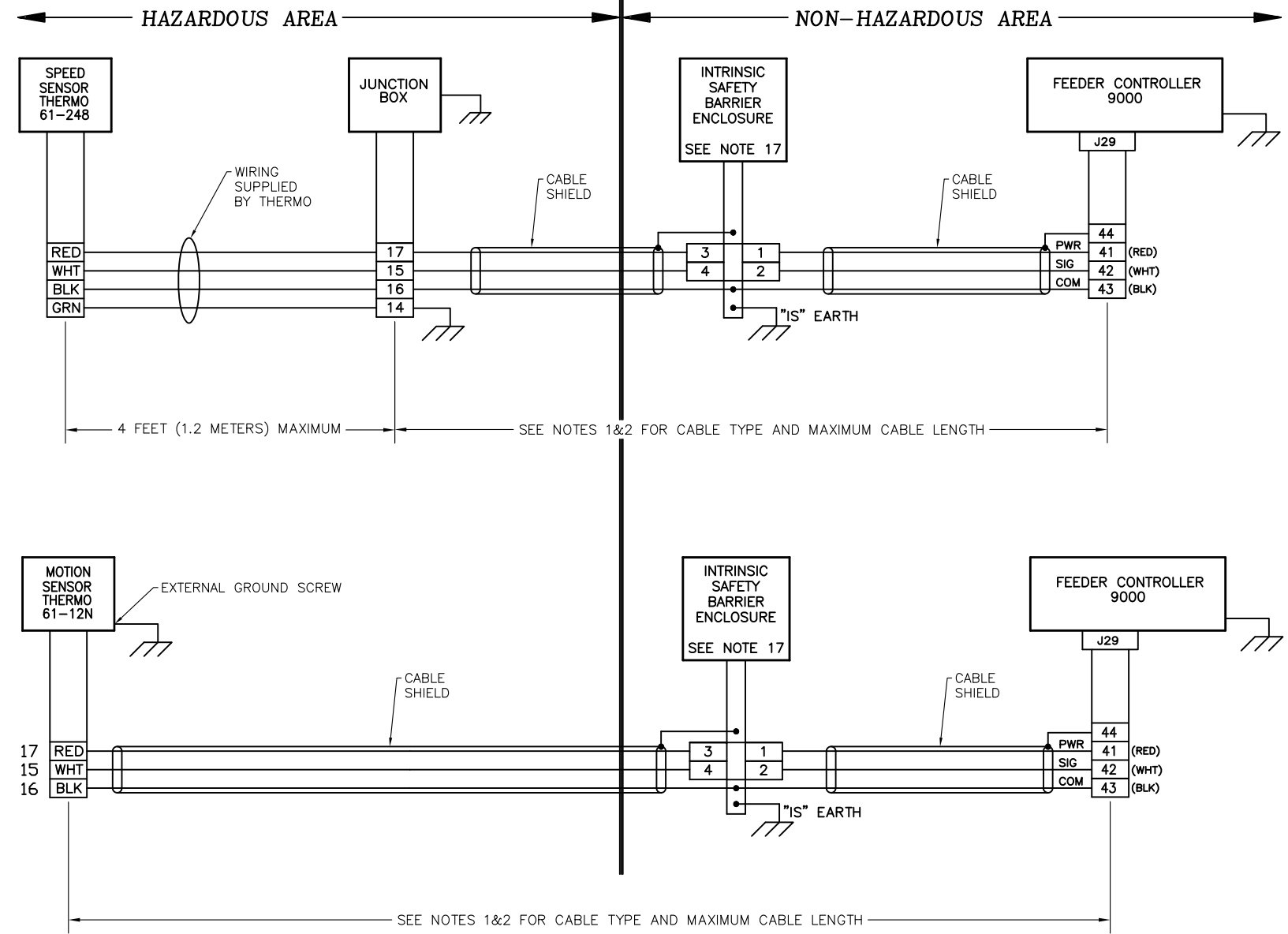

- NOTES:** READ ALL INSTRUCTIONS BEFORE WIRING SYSTEM
- USE BELDEN 8772 OR EQUIVALENT (THERMO PN 002346), 3 CONDUCTOR, 20 AWG, SHIELDED CABLE IF TOTAL LENGTH IS 500 FEET (150 METERS) OR LESS.
 - USE BELDEN 1036A OR EQUIVALENT (THERMO PN 041559), 3 CONDUCTOR, 18 AWG, SHIELDED CABLE IF TOTAL LENGTH IS 500-3000 FEET (150-915 METERS).
 - CABLES MAY BE RUN IN CONDUIT.
 - DO NOT RUN SPEED SENSOR CABLES IN THE SAME CONDUIT AS POWER WIRING.
 - CONNECT CABLE SHIELDS ONLY WHERE SHOWN.
 - EARTH GROUND ALL ELECTRICAL ENCLOSURES.
 - THE 61-248 SENSOR COMES WITH 5 FEET (1.5 METERS) OF 22 AWG WIRES ATTACHED. ALL OTHER WIRING SHOWN IN THIS DRAWING IS SUPPLIED BY OTHERS.
 - CERTIFIED FOR CLASS I, DIV. 1&2, GROUP D.
 - ENTITY PARAMETERS OF THE SENSOR:
 $U_i = 28V$
 $I_i = 93mA$
 $P_i = 660mW$
 $C_i = 0.1\mu F$
 $L_i = 0$
 - FOR ENTITY INSTALLATION SELECT A CERTIFIED BARRIER THAT SATISFIES THE FOLLOWING CONDITIONS:
 $U_o \leq U_i$
 $I_o \leq I_i$
 $P_o \leq P_i$
 $C_o \geq C_i + C_{cable}$
 $L_o \geq L_i + L_{cable}$
 - MAXIMUM NON-HAZARDOUS AREA VOLTAGE MUST NOT EXCEED 250V.
 - CANADIAN INSTALLATIONS SHOULD BE IN ACCORDANCE WITH CANADIAN ELECTRICAL CODE, PART I.
 - U.S. INSTALLATIONS SHOULD BE IN ACCORDANCE WITH ARTICLE 504 IN THE NATIONAL ELECTRICAL CODE, ANSI/NFPA 70.
 - INSTALLATIONS OUTSIDE OF THE U.S. OR CANADA SHOULD FOLLOW ALL LOCAL CODES.
 - FOR UNITS WHICH ARE CONNECTED THROUGH A GROUNDED SHUNT DIODE SAFETY BARRIER, ENSURE THAT THE SENSOR IS MOUNTED TO A SURFACE WHICH IS AT THE SAME POTENTIAL AS THE BARRIER GROUND.
 - SEE USER MANUAL FOR INSTALLATION CONDITIONS.
 - INTRINSIC SAFETY BARRIER MUST BE A CSA CERTIFIED DUAL-CHANNEL GROUNDED SHUNT-DIODE ZENER BARRIER, WHERE BOTH INDIVIDUAL CHANNELS PROVIDE THE SAME ENTITY PARAMETERS. RECOMMENDED INTRINSIC SAFETY BARRIERS THAT MEET THE REQUIREMENTS OF THIS APPLICATION INCLUDE:

MANUFACTURER	MODEL NUMBER
MTL/CROUSE-HINDS	MTL-7779+
TURCK	MZB79P
 - SPECIAL CONDITIONS FOR SAFE USE:
 -THE ENCLOSURE IS MANUFACTURED FROM A LIGHT METAL. IN RARE CASES, IGNITION SOURCES DUE TO IMPACT AND FRICTION SPARKS COULD OCCUR. THIS SHALL BE CONSIDERED DURING THE FINAL INSTALLATION.
 -THE FAULT CURRENT CANNOT EXCEED 10KA.

SEE NOTES 1&2 FOR CABLE TYPE AND MAXIMUM CABLE LENGTH

4 FEET (1.2 METERS) MAXIMUM

THIS DRAWING IS REFERENCED IN REC-4370 AND REC-4374. WHEN UPDATING THIS DRAWING, VERIFY THAT REC-4370 AND REC-4374 ARE ALSO UPDATED.

NO CHANGES WITHOUT REGULATORY APPROVAL

REV	ECO NO	MICRO	DESCRIPTION	DATE	BY	APPD
B	4227		ADD NOTE 18 AND CSA	9/23/16	EBP	TMN
A	3794		RELEASE	2/13/15	EBP	DCS

CADD DATABASE: AUTOCAD

DO NOT SCALE DWG	SCALE N/A	<small>This document is confidential and is the property of Thermo Fisher Scientific. It may not be copied or reproduced in any way without the express written consent of Thermo Fisher Scientific. This document also is an essential part of Thermo Fisher Scientific. Thermo Fisher Scientific hereby grants to you a non-exclusive license to use this document for your internal or external business purposes. Thermo Fisher Scientific reserves the right to modify the copyright law as a published work. Your using copies of this work may not copy, use or disclose the information in this work unless expressly authorized by Thermo Fisher Scientific.</small>											
REMOVE ALL BURRS AND UNNECESSARY SHARP EDGES	JOB NO												
UNLESS SPECIFIED OTHERWISE DIMENSIONS ARE IN INCHES AND (mm)	<table border="1"> <tr> <td>ENG</td> <td>DCS</td> <td>DATE</td> <td>02/04/15</td> </tr> <tr> <td>DWG</td> <td>EBP</td> <td>DATE</td> <td>02/04/15</td> </tr> <tr> <td>CHK</td> <td>DCS</td> <td>DATE</td> <td>2/4/15</td> </tr> </table>	ENG	DCS	DATE	02/04/15	DWG	EBP	DATE	02/04/15	CHK	DCS	DATE	2/4/15
ENG	DCS	DATE	02/04/15										
DWG	EBP	DATE	02/04/15										
CHK	DCS	DATE	2/4/15										
<table border="1"> <tr> <td>TOLERANCE</td> <td></td> </tr> <tr> <td>x.x [x]</td> <td>+ .06 ± 1.5 mm</td> </tr> <tr> <td>x.xx [x.x]</td> <td>+ .03 ± .8 mm</td> </tr> <tr> <td>x.xxx [x.xx]</td> <td>+ .01 ± .3 mm</td> </tr> <tr> <td>FRACT.</td> <td>1/16 ± N/A</td> </tr> <tr> <td>ANGLES</td> <td>1/2° ± 1/2°</td> </tr> </table>	TOLERANCE		x.x [x]	+ .06 ± 1.5 mm	x.xx [x.x]	+ .03 ± .8 mm	x.xxx [x.xx]	+ .01 ± .3 mm	FRACT.	1/16 ± N/A	ANGLES	1/2° ± 1/2°	NEXT ASS'Y 16700B-A001
TOLERANCE													
x.x [x]	+ .06 ± 1.5 mm												
x.xx [x.x]	+ .03 ± .8 mm												
x.xxx [x.xx]	+ .01 ± .3 mm												
FRACT.	1/16 ± N/A												
ANGLES	1/2° ± 1/2°												
CUSTOMER LOCATION	CUST ORDER NO												
USER LOCATION													

ThermoFisher SCIENTIFIC

CONTROL DRAWING, SPEED/MOTION SENSOR, 61-12N/61-248 CLASS I INSTALLATION DRAWING WITH INTRINSIC SAFETY BARRIER

PART NO	DRAWING NUMBER	REV
145406	D 07392BE041	B

© 2015 Jy Thermo Fisher Scientific

ITEM	PART NO	QTY	DESCRIPTION	DWG NO/SPEC
------	---------	-----	-------------	-------------

← HAZARDOUS AREA | NON-HAZARDOUS AREA →

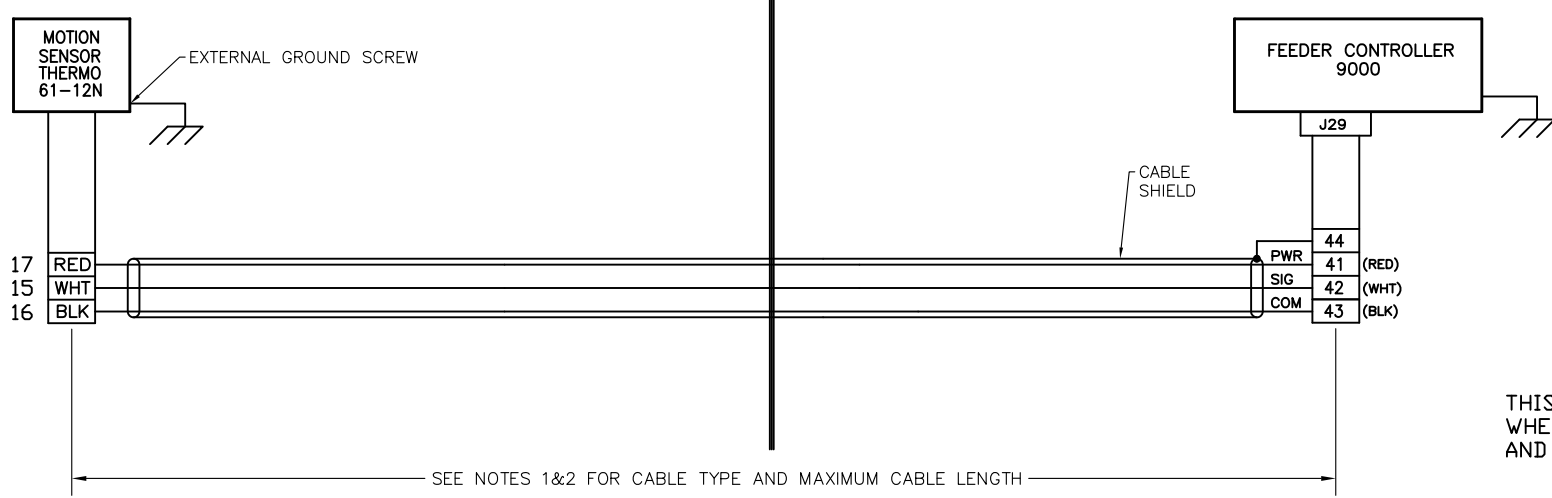
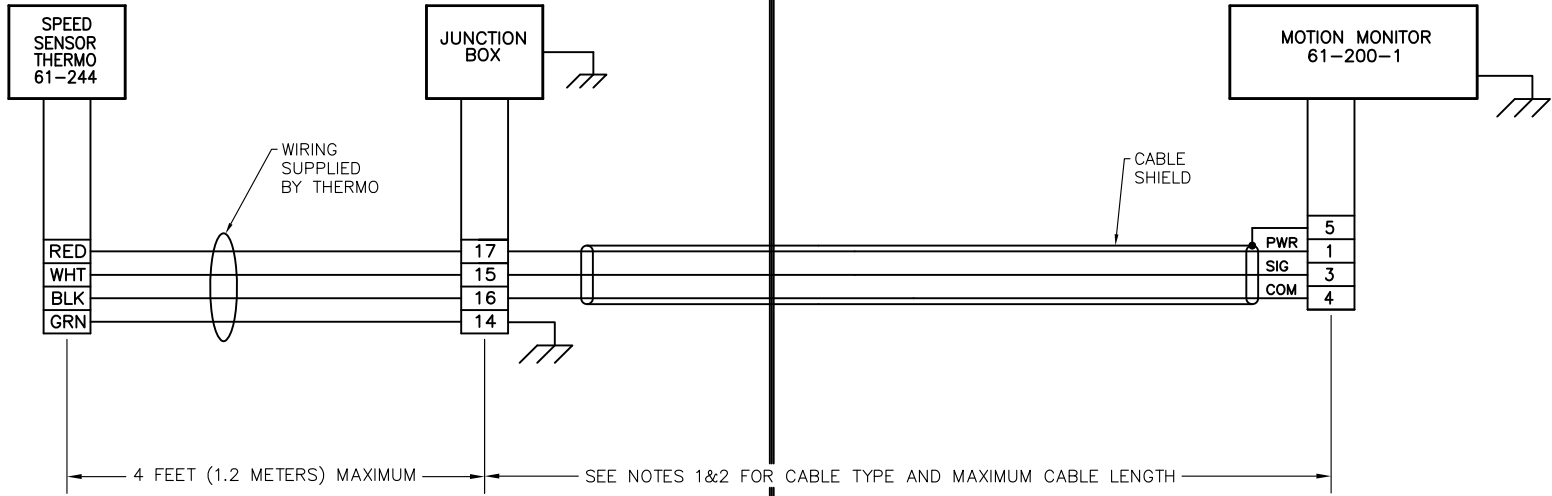
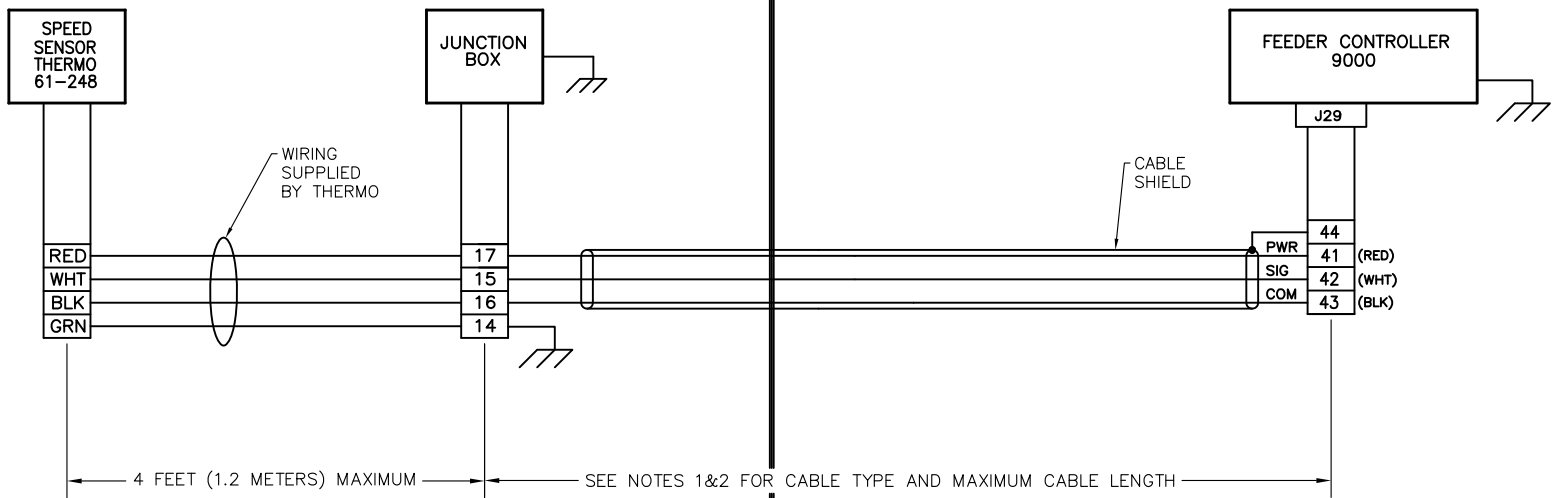

- NOTES:** READ ALL INSTRUCTIONS BEFORE WIRING SYSTEM
- USE BELDEN 8772 OR EQUIVALENT (THERMO PN 002346), 3 CONDUCTOR, 20 AWG, SHIELDED CABLE IF TOTAL LENGTH IS 500 FEET (150 METERS) OR LESS.
 - USE BELDEN 1036A OR EQUIVALENT (THERMO PN 041559), 3 CONDUCTOR, 18 AWG, SHIELDED CABLE IF TOTAL LENGTH IS 500-3000 FEET (150-915 METERS).
 - CABLES MUST BE RUN IN CONDUIT. IF SPEED/MOTION SENSOR IS FLEXIBLY MOUNTED, FLEXIBLE CONDUIT MUST BE CONNECTED TO THE SPEED/MOTION SENSOR. SEE MANUAL FOR SENSOR MOUNTING DETAILS.
 - DO NOT RUN SPEED SENSOR CABLES IN THE SAME CONDUIT AS POWER WIRING.
 - CONNECT CABLE SHIELDS ONLY WHERE SHOWN.
 - EARTH GROUND ALL ELECTRICAL ENCLOSURES.
 - THE 61-248 AND 61-244 SENSORS COME WITH 5 FEET (1.5 METERS) OF 22 AWG WIRES ATTACHED. ALL OTHER WIRING SHOWN IN THIS DRAWING IS SUPPLIED BY OTHERS.
 - CERTIFIED FOR CLASS II, DIV. 1&2, GROUPS E, F, G. CERTIFIED FOR CLASS III.
 - MAXIMUM NON-HAZARDOUS AREA VOLTAGE MUST NOT EXCEED 250V.
 - CANADIAN INSTALLATIONS SHOULD BE IN ACCORDANCE WITH CANADIAN ELECTRICAL CODE, PART I.
 - U.S. INSTALLATIONS SHOULD BE IN ACCORDANCE WITH ARTICLE 504 IN THE NATIONAL ELECTRICAL CODE, ANSI/NFPA 70.
 - INSTALLATIONS OUTSIDE OF THE U.S. OR CANADA SHOULD FOLLOW ALL LOCAL CODES.
 - SEE USER MANUAL FOR INSTALLATION CONDITIONS.
 - SPECIAL CONDITIONS FOR SAFE USE:**
 - THE UNITS FOR CLASS II INSTALLATIONS ARE INTENDED TO BE POWERED FROM A CLASS 2 LIMITED POWER SOURCES CERTIFIED TO APPLICABLE STANDARD.
 - THE ENCLOSURE IS MANUFACTURED FROM A LIGHT METAL. IN RARE CASES, IGNITION SOURCES DUE TO IMPACT AND FRICTION SPARKS COULD OCCUR. THIS SHALL BE CONSIDERED DURING THE FINAL INSTALLATION.
 - THE FAULT CURRENT CANNOT EXCEED 10KA.

NO CHANGES WITHOUT REGULATORY APPROVAL

THIS DRAWING IS REFERENCED IN REC-4370 AND REC-4374. WHEN UPDATING THIS DRAWING, VERIFY THAT REC-4370 AND REC-4374 ARE ALSO UPDATED.

REV	ECO NO	MICRO	DESCRIPTION	DATE	BY	APPD
B	4227		ADD NOTE 14 AND CSA	9/23/16	EBP	TMN
A	3794		RELEASE	2/13/15	EBP	DCS

CADD DATABASE: AUTOCAD

DO NOT SCALE DWG	SCALE N/A	<small>This document is confidential and is the property of Thermo Fisher Scientific. It may not be copied or reproduced in any way without the expressed written consent of Thermo Fisher Scientific. This document also is an essential part of Thermo Fisher Scientific. Thermo Fisher Scientific intends to use in marketing the work as confidential information. Thermo Fisher Scientific also may seek to protect this work as an unpatented copyright. In the event of other trademark or patents, Thermo Fisher Scientific intends to enforce its right in this work and the copyright here as a published work. Those having access to this work may not copy, use or disclose the information in this work unless expressly authorized by Thermo Fisher Scientific.</small>																																			
REMOVE ALL BURRS AND UNNECESSARY SHARP EDGES	JOB NO																																				
TOLERANCE	UNLESS SPECIFIED OTHERWISE DIMENSIONS ARE IN INCHES AND (mm)	<table border="1"> <tr> <td>xxx [x]</td> <td>+ .06</td> <td>+ 1.5 mm</td> <td>ENG</td> <td>EBP</td> <td>DATE</td> <td>02/13/15</td> </tr> <tr> <td>x.xx [x.x]</td> <td>+ .03</td> <td>+ .8 mm</td> <td>DWN</td> <td>EBP</td> <td>DATE</td> <td>02/13/15</td> </tr> <tr> <td>x.xxx [x.xx]</td> <td>.01</td> <td>+ .3 mm</td> <td>CHK</td> <td>DCS</td> <td>DATE</td> <td>2/13/15</td> </tr> <tr> <td>FRACT.</td> <td>+ 1/16</td> <td>N/A</td> <td></td> <td></td> <td></td> <td></td> </tr> <tr> <td>ANGLES</td> <td>+ 1/2°</td> <td>+ 1/2°</td> <td></td> <td></td> <td></td> <td></td> </tr> </table>	xxx [x]	+ .06	+ 1.5 mm	ENG	EBP	DATE	02/13/15	x.xx [x.x]	+ .03	+ .8 mm	DWN	EBP	DATE	02/13/15	x.xxx [x.xx]	.01	+ .3 mm	CHK	DCS	DATE	2/13/15	FRACT.	+ 1/16	N/A					ANGLES	+ 1/2°	+ 1/2°				
xxx [x]	+ .06	+ 1.5 mm	ENG	EBP	DATE	02/13/15																															
x.xx [x.x]	+ .03	+ .8 mm	DWN	EBP	DATE	02/13/15																															
x.xxx [x.xx]	.01	+ .3 mm	CHK	DCS	DATE	2/13/15																															
FRACT.	+ 1/16	N/A																																			
ANGLES	+ 1/2°	+ 1/2°																																			
NEXT ASS'Y	16700B-A001																																				
CUST ORDER NO																																					
CUSTOMER LOCATION																																					
USER LOCATION																																					

ThermoFisher SCIENTIFIC

CONTROL DRAWING, SPEED/MOTION SENSOR, 61-12N/61-244/61-248 CLASS II & III INSTALLATIONS

PART NO	DRAWING NUMBER	REV
145407	D 07392BE042	B

NON-HAZARDOUS AREA

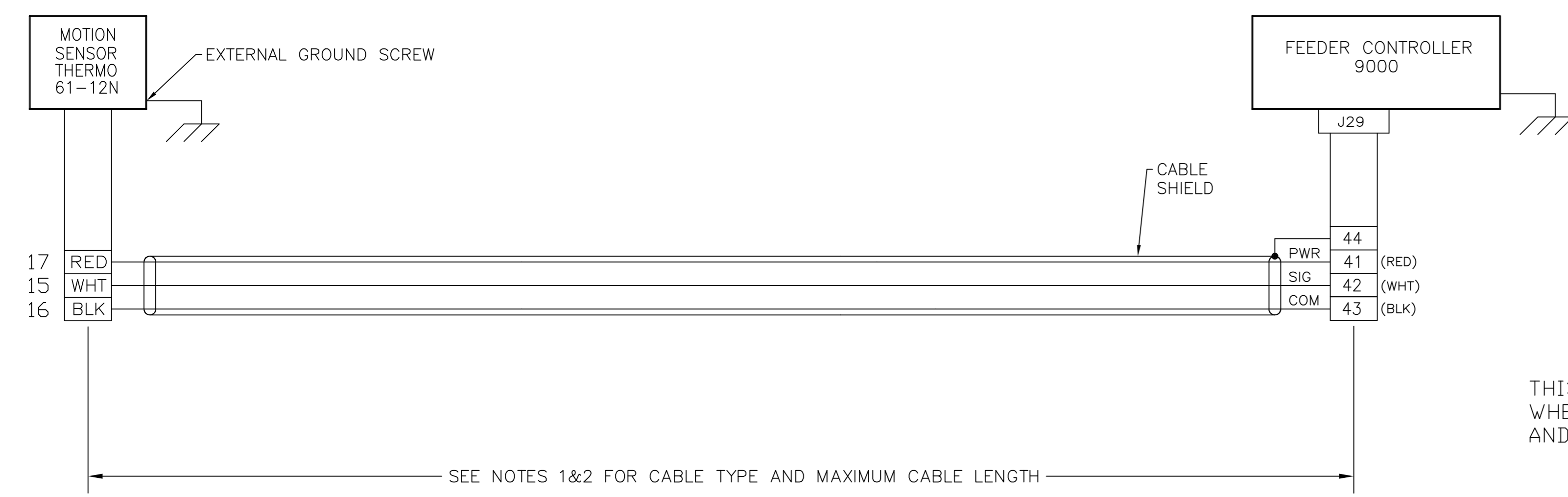
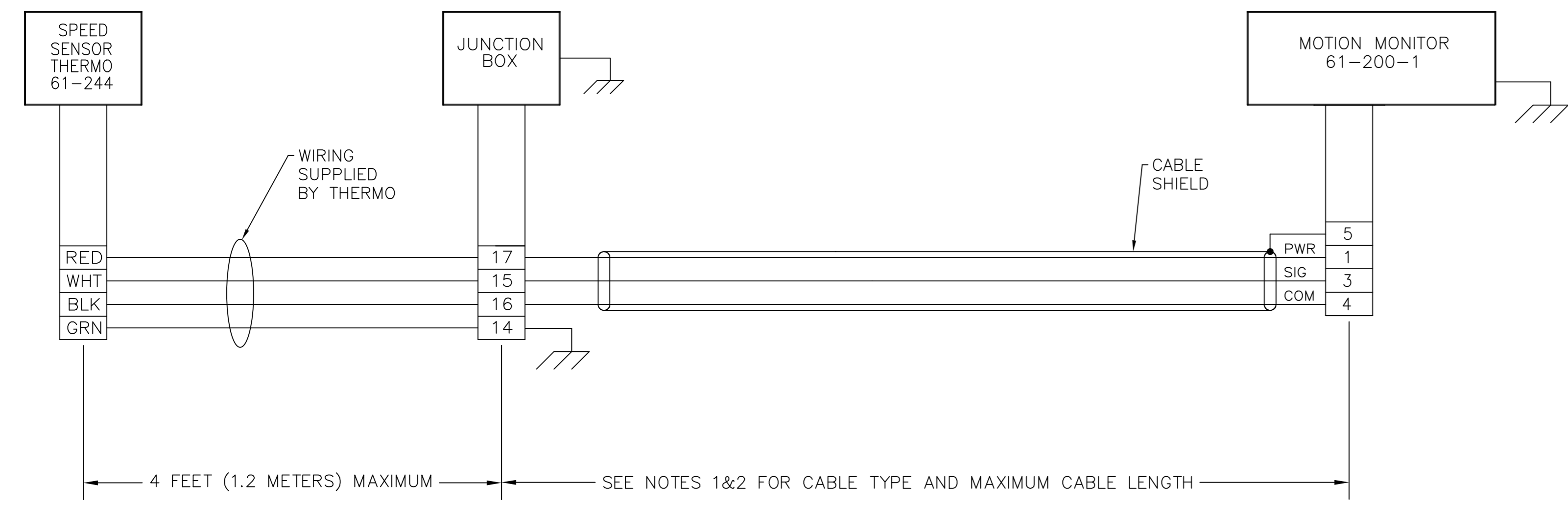
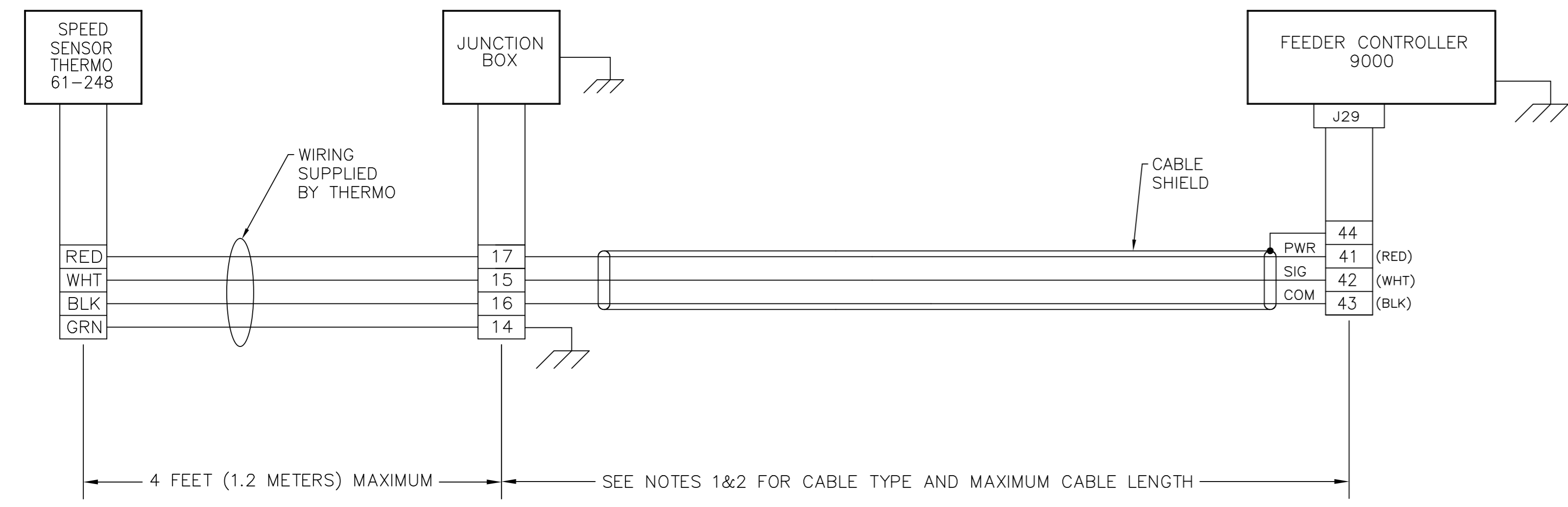

- NOTES: READ ALL INSTRUCTIONS BEFORE WIRING SYSTEM
- USE BELDEN 8772 OR EQUIVALENT (THERMO PN 002346), 3 CONDUCTOR, 20 AWG, SHIELDED CABLE IF TOTAL LENGTH IS 500 FEET (150 METERS) OR LESS.
 - USE BELDEN 1036A OR EQUIVALENT (THERMO PN 041559), 3 CONDUCTOR, 18 AWG, SHIELDED CABLE IF TOTAL LENGTH IS 500-3000 FEET (150-915 METERS).
 - CABLES MAY BE RUN IN CONDUIT. IF SPEED/MOTION SENSOR IS FLEXIBLY MOUNTED, FLEXIBLE CONDUIT MUST BE CONNECTED TO THE SPEED/MOTION SENSOR. SEE MANUAL FOR SENSOR MOUNTING DETAILS.
 - DO NOT RUN SPEED SENSOR CABLES IN THE SAME CONDUIT AS POWER WIRING.
 - CONNECT CABLE SHIELDS ONLY WHERE SHOWN.
 - EARTH GROUND ALL ELECTRICAL ENCLOSURES.
 - THE 61-248 AND 61-244 SENSORS COME WITH 5 FEET (1.5 METERS) OF 22 AWG WIRES ATTACHED. ALL OTHER WIRING SHOWN IN THIS DRAWING IS SUPPLIED BY OTHERS.
 - MAXIMUM NON-HAZARDOUS AREA VOLTAGE MUST NOT EXCEED 250V.
 - CANADIAN INSTALLATIONS SHOULD BE IN ACCORDANCE WITH CANADIAN ELECTRICAL CODE, PART I.
 - U.S. INSTALLATIONS SHOULD BE IN ACCORDANCE WITH ARTICLE 504 IN THE NATIONAL ELECTRICAL CODE, ANSI/NFPA 70.
 - INSTALLATIONS OUTSIDE OF THE U.S. OR CANADA SHOULD FOLLOW ALL LOCAL CODES.
 - SEE USER MANUAL FOR INSTALLATION CONDITIONS.

THIS DRAWING IS REFERENCED IN REC-4370 AND REC-4374. WHEN UPDATING THIS DRAWING, VERIFY THAT REC-4370 AND REC-4374 ARE ALSO UPDATED.

CADD DATABASE: AUTOCAD

DO NOT SCALE DWG		SCALE	N/A
REMOVE ALL BURRS AND UNNECESSARY SHARP EDGES		JOB NO	
UNLESS SPECIFIED OTHERWISE DIMENSIONS ARE IN INCHES AND [mm]		ENG	EBP DATE 08/20/15
X.X [X]	± .06 ± 1.5 mm	DWN	EBP DATE 08/20/15
X.XX [X.X]	± .05 ± .9 mm	CHK	DCS DATE 8/20/15
X.XXX [X.XX]	± .01 ± .3 mm		
FRACT.	± 1/16 ± N/A		
ANGLES	± 1/2° ± 1/2°		
NEXT ASS'Y 16700B-A001			
CUST ORDER NO			
CUSTOMER LOCATION			
USER LOCATION			

Thermo Fisher SCIENTIFIC

CONTROL DRAWING, SPEED/MOTION SENSOR, 61-12N/61-244/61-248 FOR NON-HAZARDOUS AREA INSTALLATIONS

PART NO	DRAWING NUMBER	REV
147488	D07392BE043	A

© 2015, by Thermo Fisher Scientific

REV	ECO NO	MICRO	DESCRIPTION	DATE	BY	APPD
A	3794		RELEASE	8/20/15	EBP	DCS